

SECTION A-A

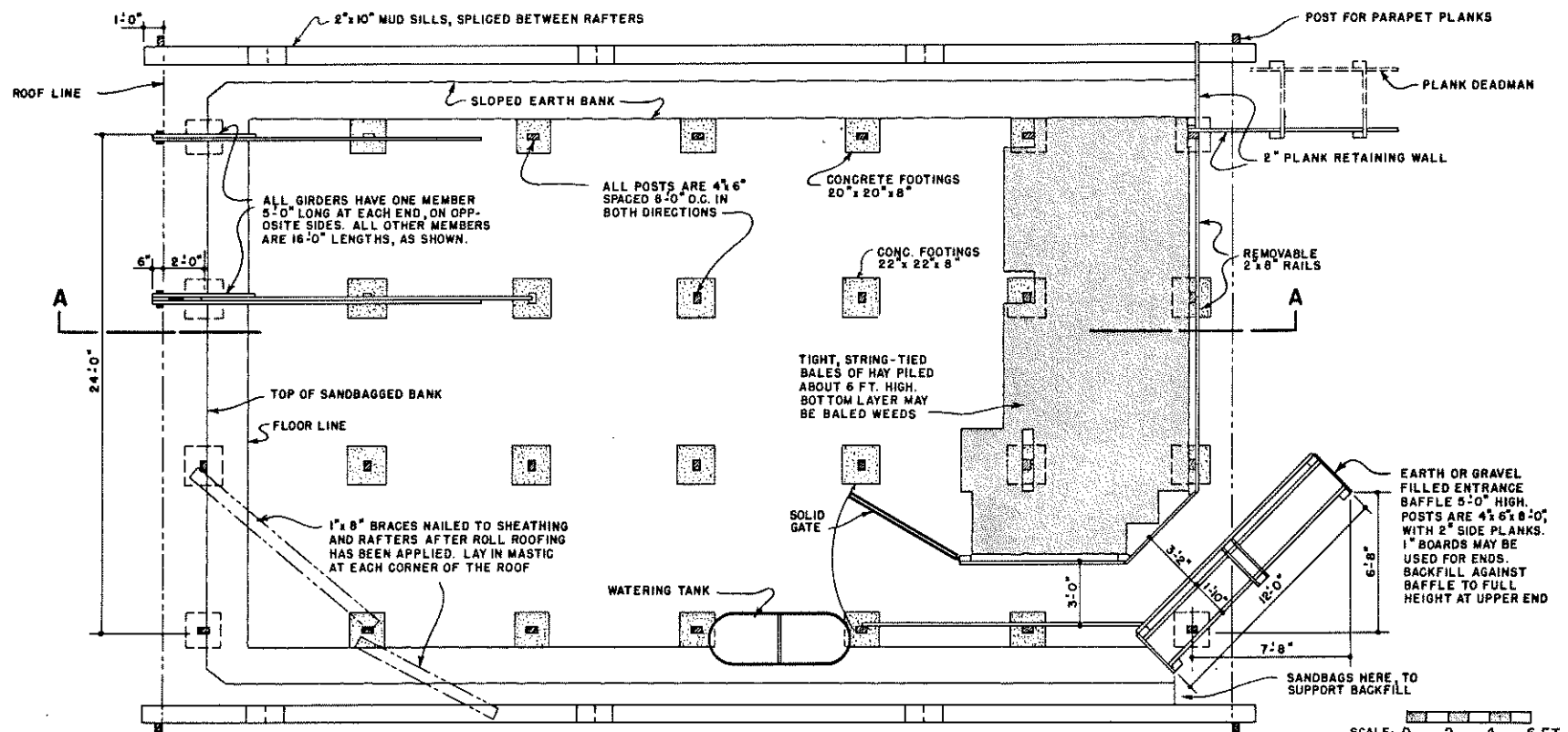

3-BAY PLAN

MOST ROOF FRAMING NOT SHOWN

ALL LUMBER TO BE FULL SIZE ROUGH SAWN, PRESSURE-TREATED WITH PRESERVATIVE

FASTENINGS AND OTHER STEEL PARTS SHALL BE HOT-DIP GALVANIZED

SCALE: 0 2 4 6 FT.

COOPERATIVE EXTENSION WORK IN
 AGRICULTURE AND HOME ECONOMICS
 DEPARTMENT OF AGRICULTURAL ENGINEERING
 UNIVERSITY OF MARYLAND
 AND
 UNITED STATES DEPARTMENT OF AGRICULTURE COOPERATING

BUNKER-TYPE FALLOUT SHELTER
 FOR BEEF CATTLE

USDA '63 EX. 5950 SHEET 1 OF 2

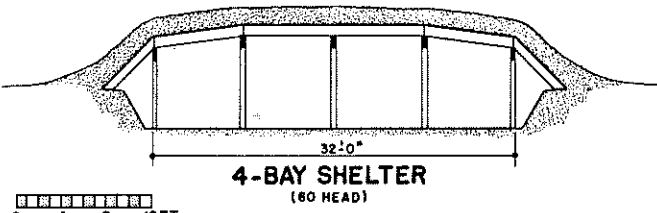
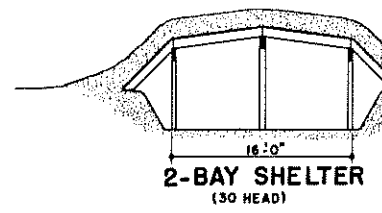
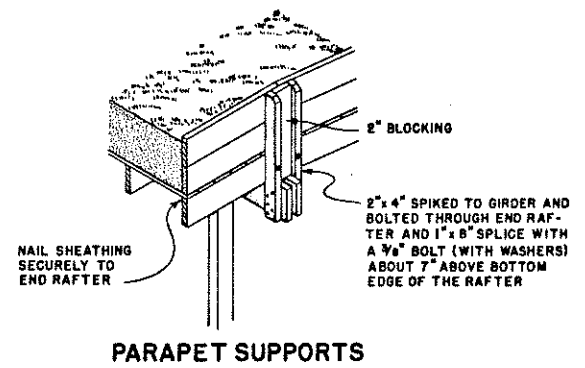
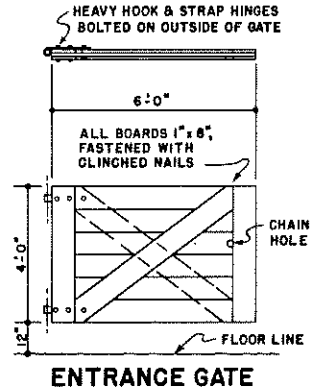
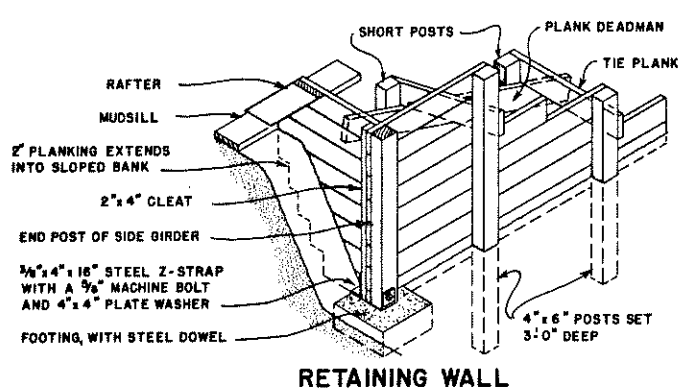
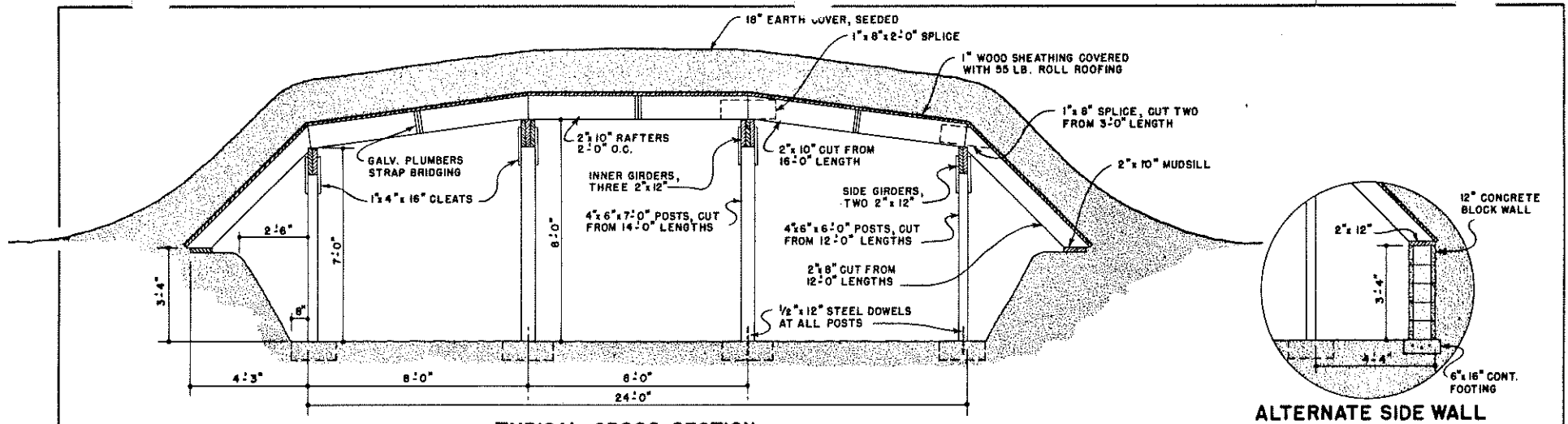

SCALE: 0 4 8 12 FT.

0 1 2 3 4 FT., EXCEPT AS NOTED

COOPERATIVE EXTENSION WORK IN
 AGRICULTURE AND HOME ECONOMICS
 DEPARTMENT OF AGRICULTURAL ENGINEERING
 UNIVERSITY OF MARYLAND
 AND
 UNITED STATES DEPARTMENT OF AGRICULTURE COOPERATING

BUNKER-TYPE FALLOUT SHELTER
 FOR BEEF CATTLE

| | | | |
|------|-----|----------|--------------|
| USDA | '63 | EX. 5950 | SHEET 2 OF 2 |
|------|-----|----------|--------------|