

FRONT ELEVATION

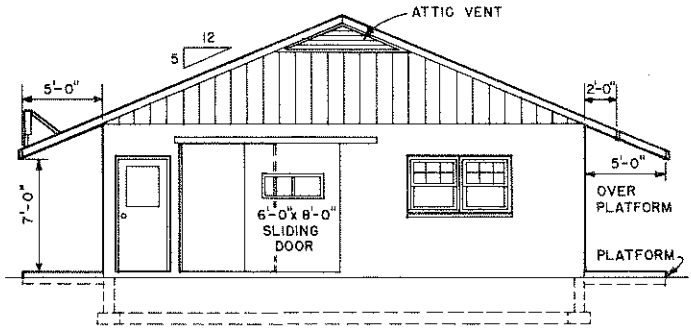

RIGHT SIDE ELEVATION

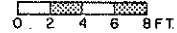
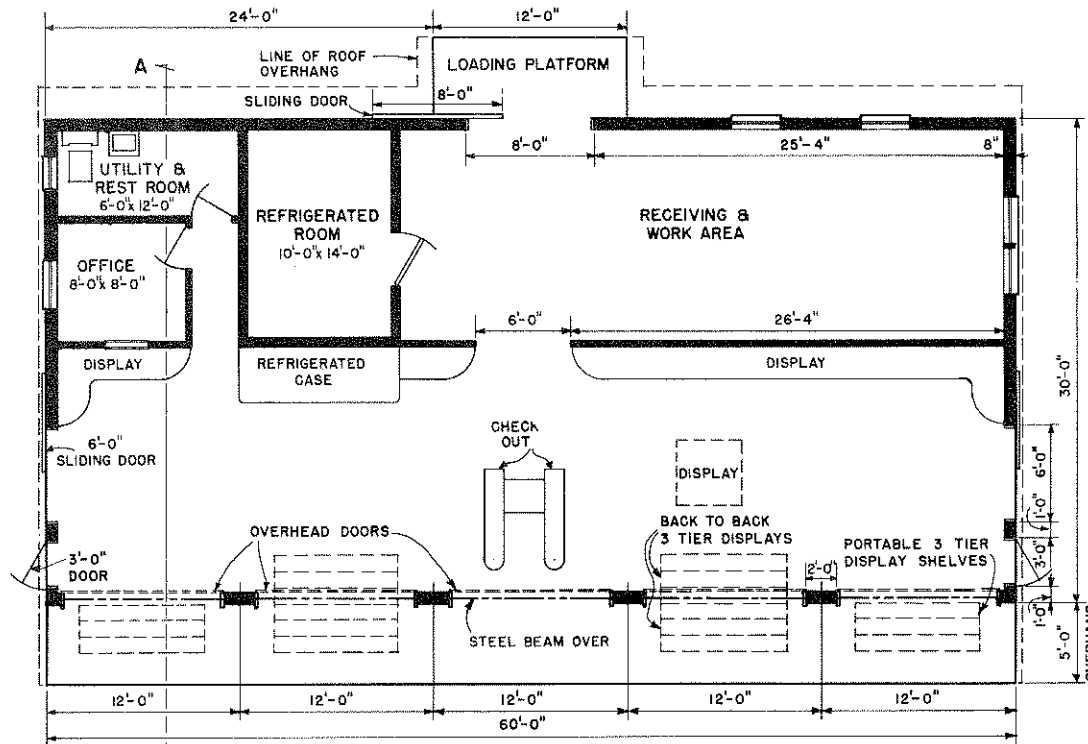
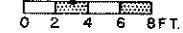

PLAN

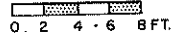

NOTE: DIMENSIONS SHOWN ARE NOMINAL,
1"x12" LUMBER MAY BE USED.

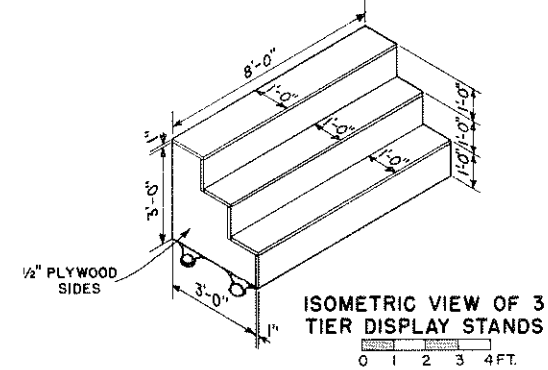

ISOMETRIC VIEW OF 3
TIER DISPLAY STANDS

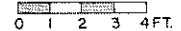

COOPERATIVE EXTENSION WORK IN
AGRICULTURE AND HOME ECONOMICS
DEPARTMENT OF AGRICULTURAL ENGINEERING
UNIVERSITY OF MARYLAND
AND
UNITED STATES DEPARTMENT OF AGRICULTURE COOPERATING

ROADSIDE MARKET

N.J. '67 EX. 6027 SHEET 1 OF 3

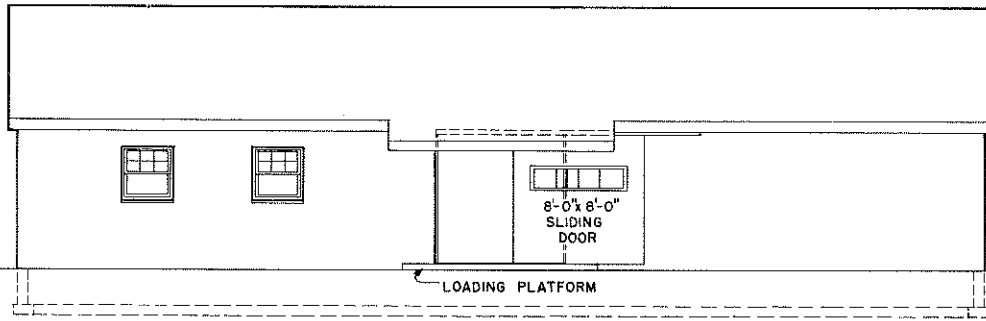

REAR ELEVATION

0 2 4 6 8 FT.

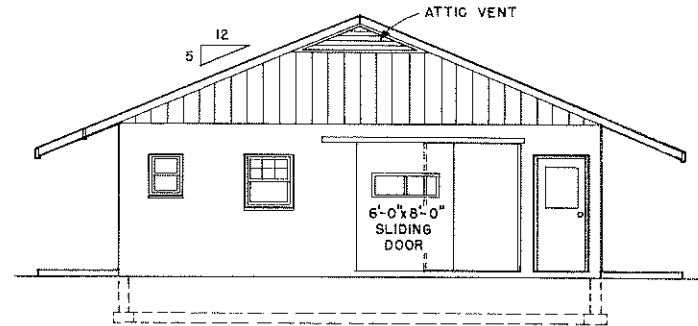

LEFT SIDE ELEVATION

0 2 4 6 8 FT.

NOTE: REINFORCED CONCRETE LINTELS OVER END WALL OPENINGS.

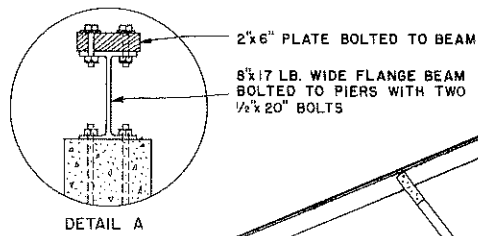

ALTERNATE ROOF CONSTRUCTION
TRUSSES 4'-0" O.C.
NAILERS 2x4", 2'-0" O.C.
STEEL OR ALUM. ROOFING

DESIGN LOAD 30 P.S.F. TOTAL

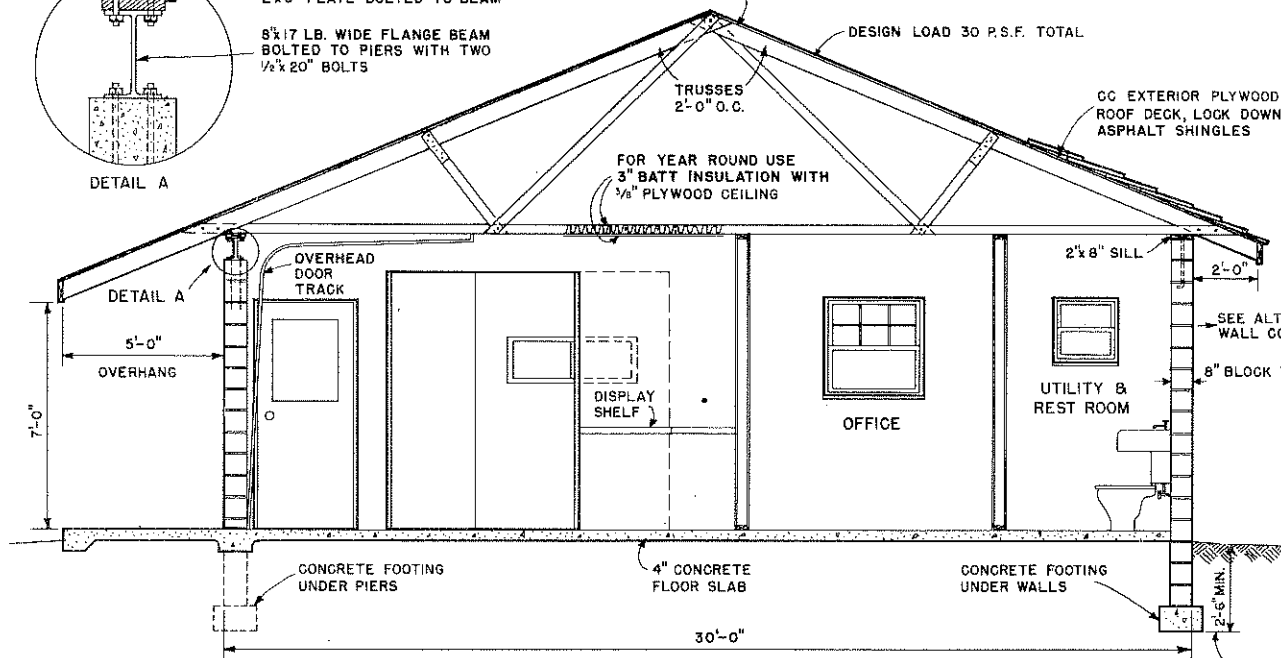

ALTERNATE STUD WALL CONSTRUCTION

0 1 2 3 4 FT.

NOTE: PIERS ARE CAST CONCRETE OR PILASTER BLOCKS WITH CORES FILLED. REINFORCE WITH TWO 1/2" RODS WHICH EXTEND INTO FOOTING.

SECTION A-A

0 1 2 3 4 FT.

COOPERATIVE EXTENSION WORK IN
AGRICULTURE AND HOME ECONOMICS
DEPARTMENT OF AGRICULTURAL ENGINEERING
UNIVERSITY OF MARYLAND
AND
UNITED STATES DEPARTMENT OF AGRICULTURE COOPERATING

ROADSIDE MARKET

N.J. '67 EX. 6027 SHEET 2 OF 3

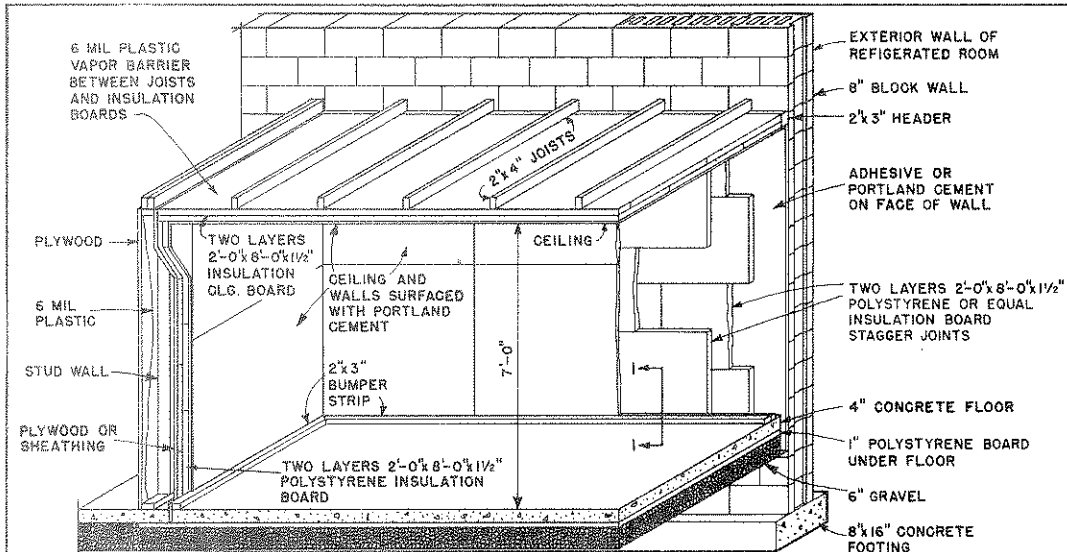

CUT AWAY VIEW THROUGH REFRIGERATED ROOM

0 1 2 3 FT.

NOTE:
REFRIGERATION ROOM CAPACITY:
1000 CU. FT.
200-300 BUSHELS
REFRIGERATION - REQUIRED
HOLDING TEMP.
56" — 3/4 TON
32"-36" — 1 TON

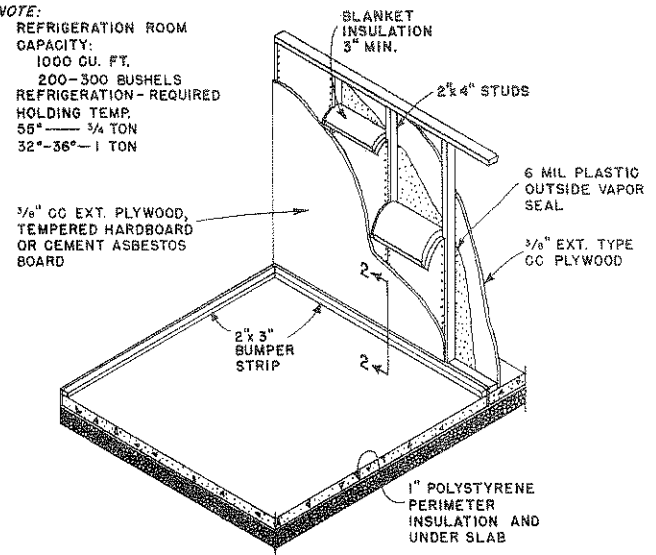

ALTERNATE VIEW THROUGH STUD WALL CONSTRUCTION

0 1 2 3 4 FT.

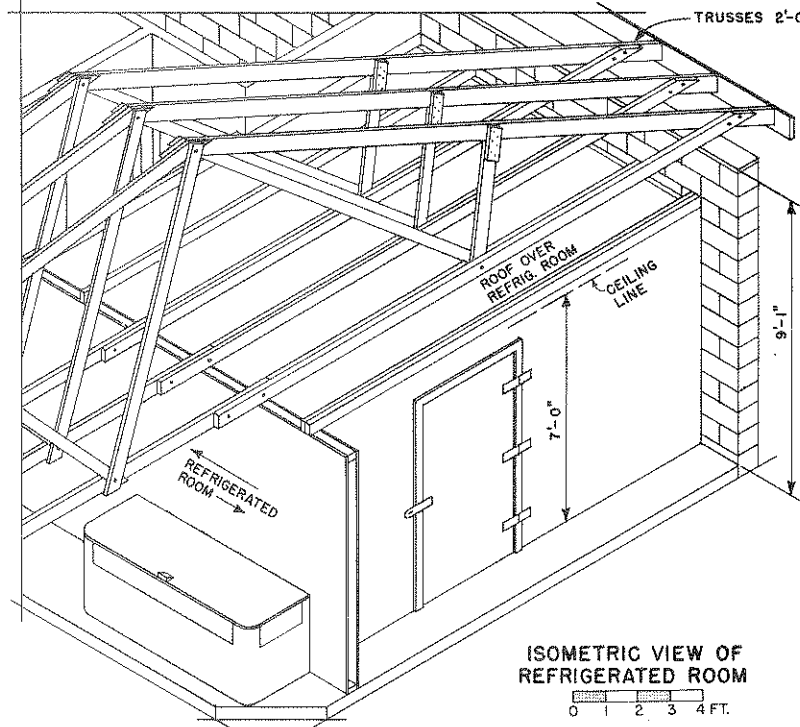

ISOMETRIC VIEW OF REFRIGERATED ROOM

0 1 2 3 4 FT.

SCORE CEMENT IN 3'-6"x3'-6" SQUARES TO CONTROL CRACKING

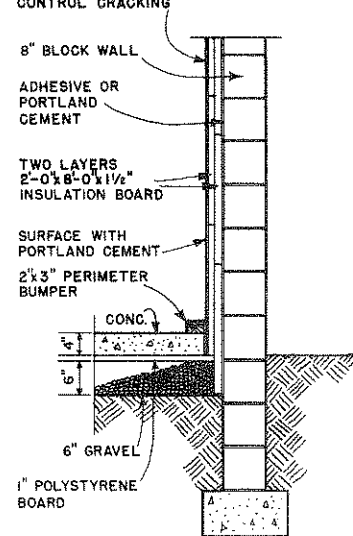

SECTION 1-1

0 1 2 FT.

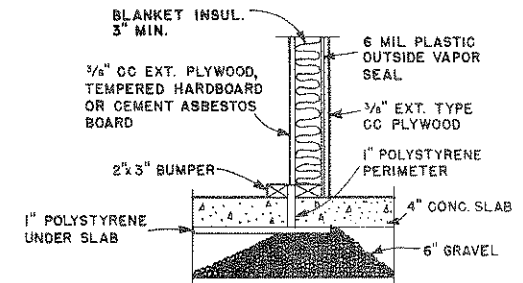

SECTION 2-2

0 1 FT.

COOPERATIVE EXTENSION WORK IN AGRICULTURE AND HOME ECONOMICS
DEPARTMENT OF AGRICULTURAL ENGINEERING
UNIVERSITY OF MARYLAND

AND UNITED STATES DEPARTMENT OF AGRICULTURE COOPERATING

ROADSIDE MARKET

N.J. '67 EX. 6027 SHEET 3 OF 3