

FLOOR PLAN

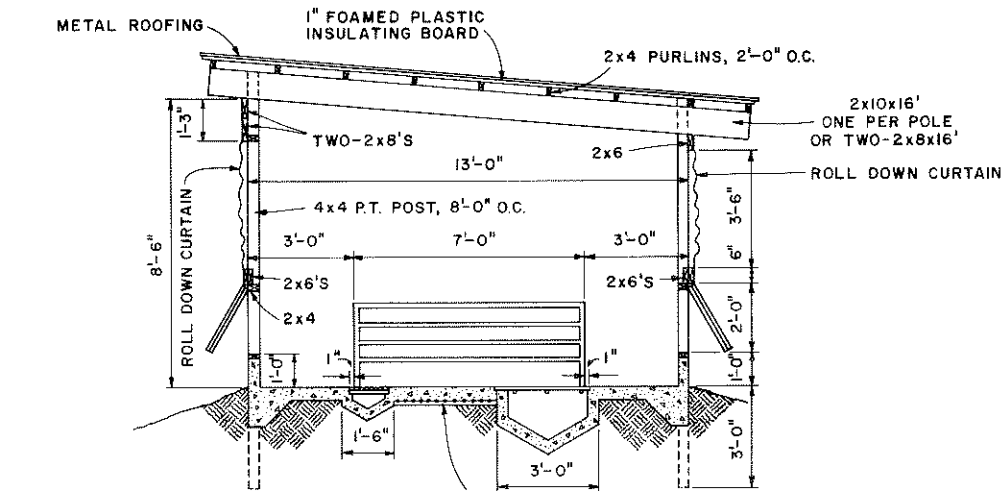

SECTION "A-A"

SCALE: 3/8" = 1'-0"



INSULATING BOARD AND HEATING CABLE, STAPLED TO BOARD BEFORE CONCRETE IS POURED.

NOTE:
CONSULT LOCAL HEALTH AND BUILDING CODE AUTHORITIES BEFORE STARTING CONSTRUCTION.

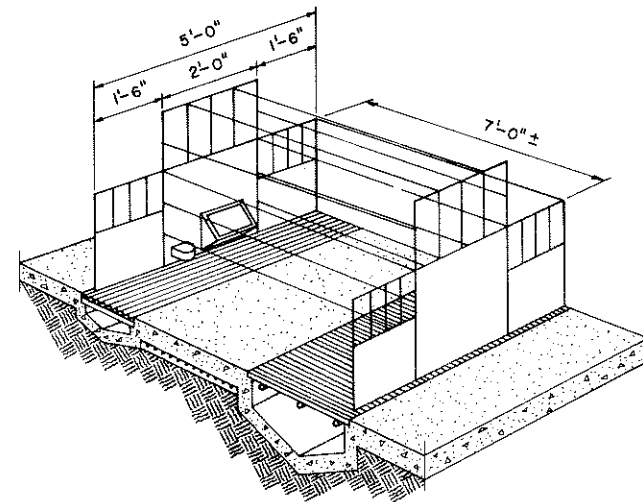

PERSPECTIVE
TYPICAL PEN

COOPERATIVE EXTENSION WORK IN
AGRICULTURE AND HOME ECONOMICS

AND
UNITED STATES DEPARTMENT OF AGRICULTURE COOPERATING

FARROWING HOUSE
FOR SOWS

MISS. '75 6225 SHEET 1 OF 2

BASED ON: MISS. STATE UNIV. PLAN NO. 6076-A

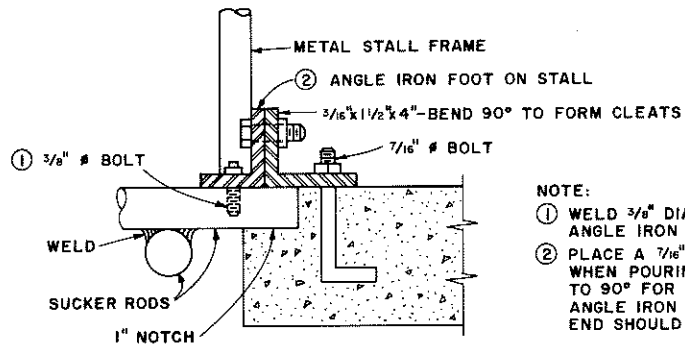

DETAIL FOR ANCHORING STALLS
 SCALE: NONE

NOTE:

- ① WELD $\frac{3}{8}$ " DIAMETER BOLT TO RODS, DRILL ANGLE IRON FOOT OF STALL AND BOLT.
- ② PLACE A $\frac{7}{16}$ " DIAMETER BOLT IN CONCRETE WHEN POURING. BEND A $\frac{3}{16} \times \frac{1}{2}$ " IRON PIECE TO 90° FOR A CLEAT. DRILL AND BOLT TO ANGLE IRON FOOT. ONE ANCHOR AT EACH END SHOULD BE ADEQUATE.

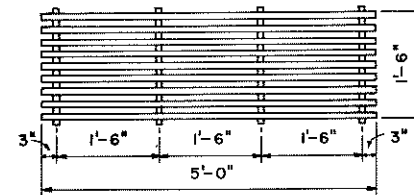
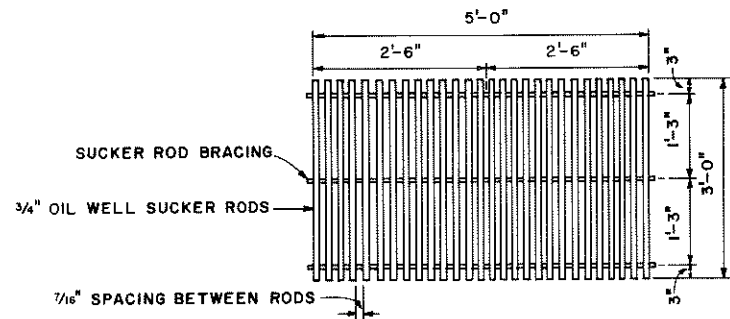

SLAT DETAIL
 SCALE: NONE

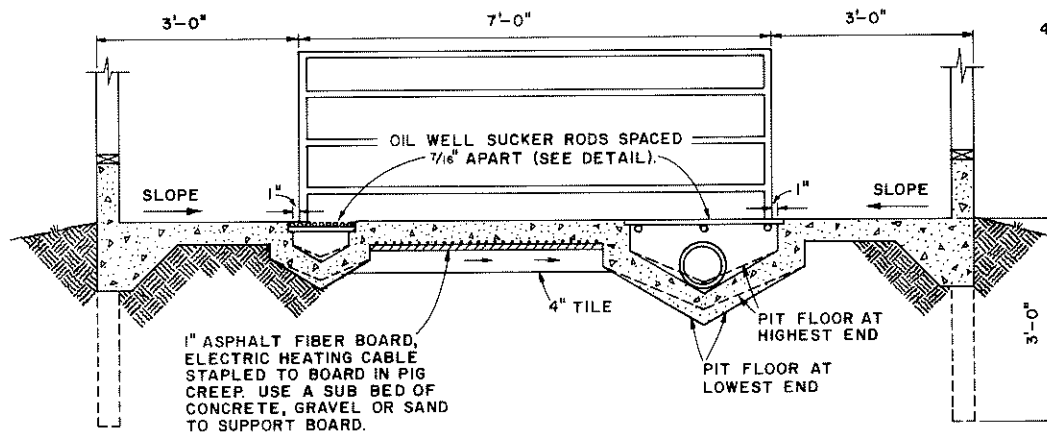

SECTION "B-B"

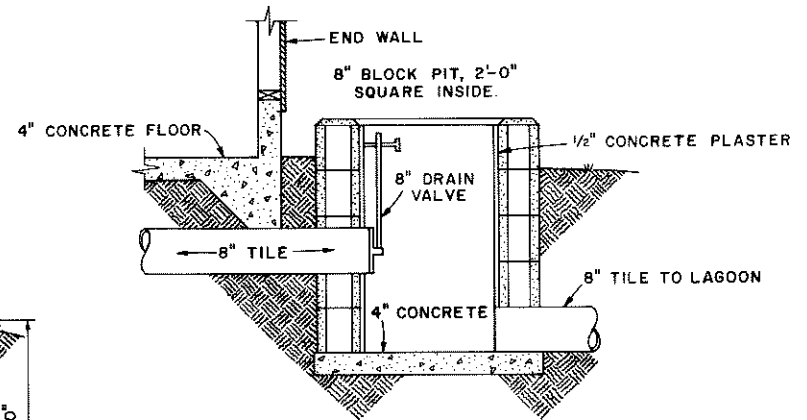

SECTION "C-C"

COOPERATIVE EXTENSION WORK IN AGRICULTURE AND HOME ECONOMICS		
AND UNITED STATES DEPARTMENT OF AGRICULTURE COOPERATING		
FARROWING HOUSE FOR SOWS		
MISS. '75	6225	SHEET 2 OF 2