

**BASIC FLOOR PLAN**

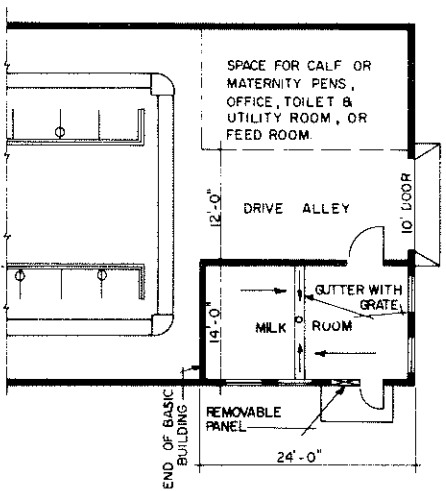

**ALTERNATE END**

(MILK ROOM WITHIN MAIN BARN)

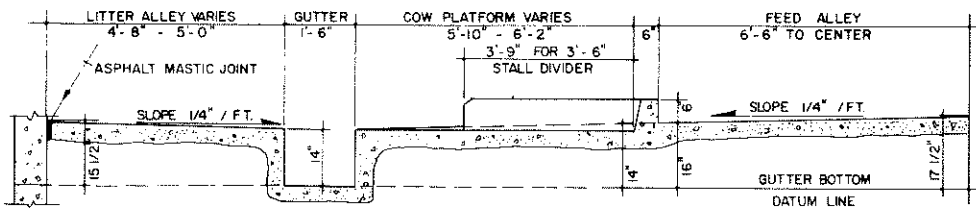

**FLOOR HALF SECTION**

**NOTES**

1. PLAN IS DESIGNED TO ALLOW FEEDING OF SILAGE WITH A SELF-UNLOADING WAGON THROUGH THE CENTER FEED ALLEY.
2. PROVIDE VENTILATION RATE OF AT LEAST 120 CFM PER 1000 LB OF ANIMAL BODY WEIGHT. 30 CFM PER 1000 LB SHOULD BE CONTROLLED THERMOSTATICALLY FOR CONTINUOUS WINTER VENTILATION IF COWS WILL BE HOUSED IN THE BUILDING DURING SUMMER MONTHS, MAXIMUM OF 250 CFM PER 1000 LB BODY WEIGHT SHOULD BE PROVIDED.
3. CONSULT MANUFACTURER OF EQUIPMENT FOR INSTALLATION DETAILS. DESIGN IS BASED ON USE OF TIE STALLS FOR LARGE ANIMALS.
4. CONSULT LOCAL POWER SUPPLIER AND ELECTRICIAN ON SIZE AND TYPE OF ELECTRIC SERVICE AND WIRING.

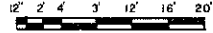

COOPERATIVE EXTENSION WORK IN AGRICULTURE AND HOME ECONOMICS		
AND UNITED STATES DEPARTMENT OF AGRICULTURE COOPERATING		
40' WIDE, CLEAR SPAN, FACE-IN STALL BARN		
MASS. '80	EX. 6326	SHEET 1 OF 2

**PIECE LIST, NOTES & SPECIFICATIONS**

1. 1"x2" FOOTING, KEY FORM WITH OILED 1"x2"
2. 8" WIDE CONCRETE FOUNDATION. SPECIFY CONCRETE MIX WITH 3/4" MAXIMUM AGGREGATE, 6 1/2 SACKS OF CEMENT PER CUBIC YARD & 6-GALLON WATER-CEMENT RATIO.
3. 1/2"x1-6" ANCHOR BOLT, 6" O.C. AND IN WALLS AT DOORS.
4. 18"x6 MIL BLACK POLYETHYLENE FILM & SILL INSULATION. FASTEN FREE EDGE OF FILM UNDER INTERNAL SHEATHING
5. 2"x6" SILL
6. 2"x6"x8'-0" STUD 2'-0" O.C.
7. 2"x6" PLATE
8. 40' SPAN 5 IN 12 SLOPE TRUSS, 4'-0" O.C.
9. 2"x6"x8'-6" WIND BRACE 12'-0" O.C.
10. 2"x4"x12" PURLIN, 2'-0" O.C.
11. SHEET METAL ROOFING
12. 2"x4"x2'-0" CLEAT USE ONLY IF PLYWOOD SHEET SIDING WILL BE USED, 4'-0" O.C.
13. 2"x4" INSULATION STOP. CUT TO FIT BETWEEN TRUSSES
14. 1"x10" SOFFIT
15. 1"x4" SOFFIT
16. 1"x12" FASCIA
17. EXTERIOR SHEATHING 1" BOARDS OR 1/2" EXTERIOR PLYWOOD
18. WALL INSULATION: 2" (PREFERABLY 3") INORGANIC BATT OR EQUIVALENT
19. WALL VAPOR BARRIER: 6 MIL BLACK POLYETHYLENE FILM OR EQUIVALENT
20. INTERIOR SHEATHING 3/8" EXTERIOR PLYWOOD, 1/4" ASBESTOS CEMENT BOARD BACKED WITH 1/4" EXTERIOR PLYWOOD IN ANIMAL CONTACT AREA, OR 1" BOARDS.
21. CEILING INSULATION: 3" (PREFERABLE 4") INORGANIC FIBER BATT OR FILL OR EQUIVALENT
22. CEILING VAPOR BARRIER: 6 MIL BLACK POLYETHYLENE FILM. (NOT USED WITH ALUMINUM CEILING)
23. CEILING ALUMINUM ROOFING MATERIAL (SEAL JOINTS WITH MASTIC FOR VAPOR BARRIER), 3/8" EXTERIOR PLYWOOD WITH 2"x4" BATTENS OVER LONGITUDINAL JOINTS 1/2" EXT. PLYWOOD WITHOUT BATTEN STRIPS (USE NON-CORROSIVE NAILS) OR ASBESTOS CEMENT BOARD OVER FURRING STRIPS
24. 1" BOARD OR 3/4" EXTERIOR PLYWOOD SLOT INLET CONTROL DOOR BOLT TO INSULATION STOP WITH CADMIUM PLATED BOLTS & WING NUTS. SLOT HOLES FOR SEASONAL ADJUSTMENT.
25. CONCRETE FLOOR: 1 1/2" MAXIMUM AGGREGATE, 6-SACKS PER CUBIC YARD, 6-GALLON WATER-CEMENT RATIO, 3" SLUMP

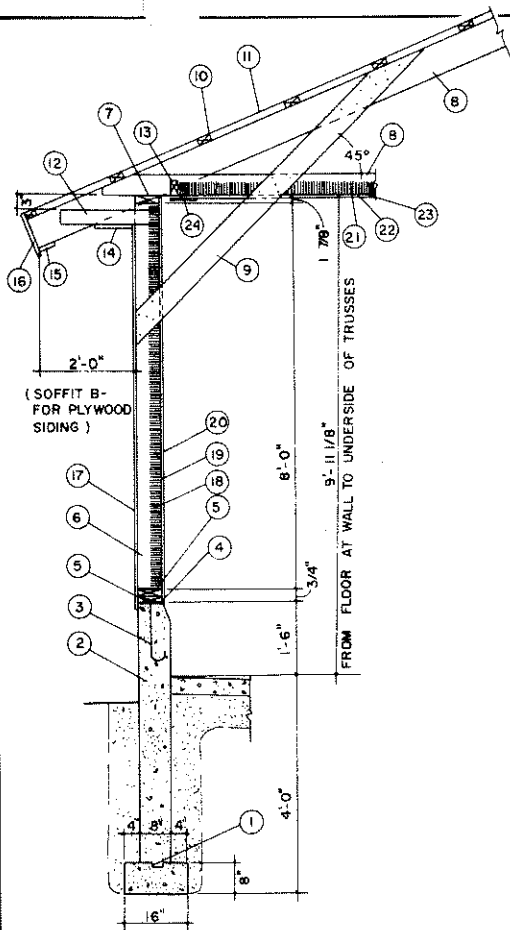

**WALL SECTION C-C**

SCALE 1/2" = 1'-0"

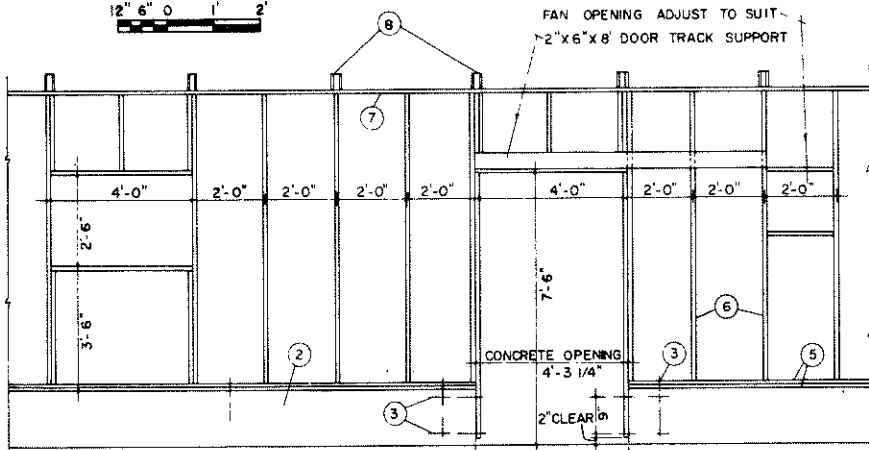

**TYPICAL WALL FRAMING DETAIL**

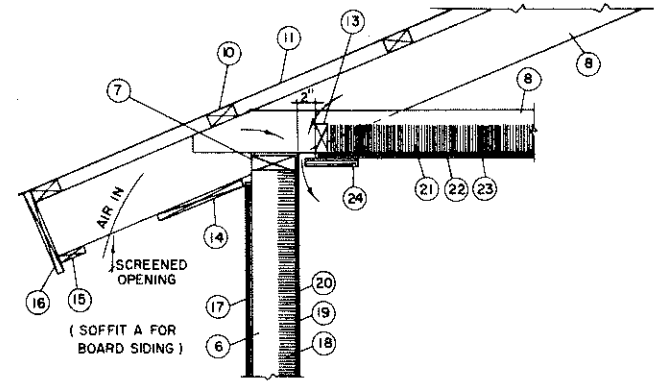

**VENTILATION SLOT DETAIL**

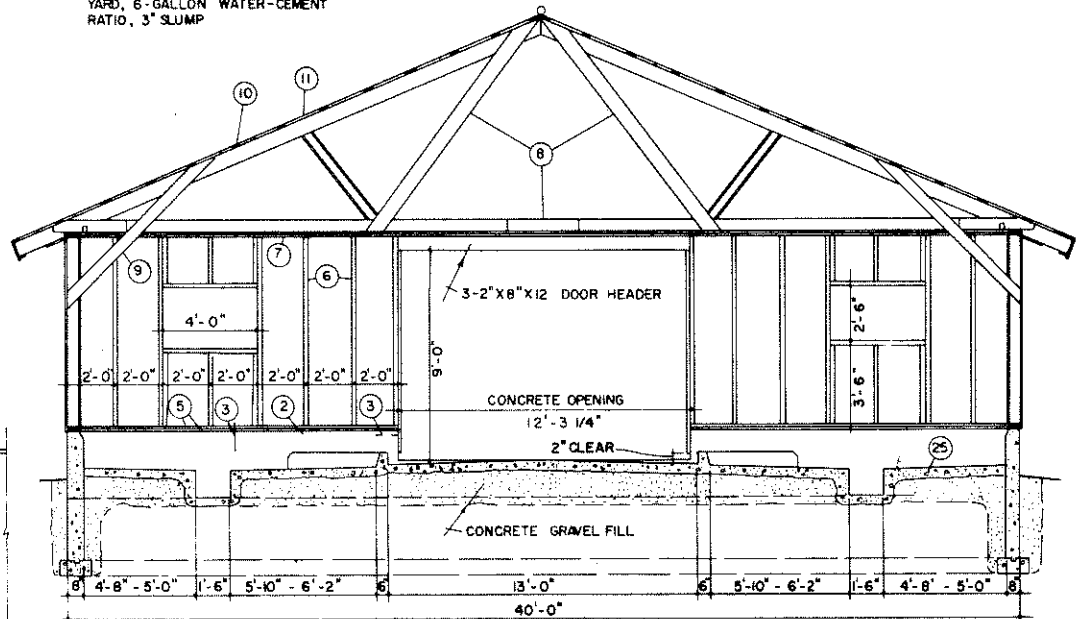

**SECTION A-A**

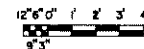

COOPERATIVE EXTENSION WORK IN  
AGRICULTURE AND HOME ECONOMICS

AND  
UNITED STATES DEPARTMENT OF AGRICULTURE COOPERATING

40' WIDE, CLEAR SPAN, FACE-IN  
STALL BARN

MASS. '80 EX. 6326 SHEET 2 OF 2