

PLAN PREPARED UNDER THE RURAL HOUSING PROJECT - BUREAU OF HOME ECONOMICS AND AGRICULTURAL ENGINEERING - U.S. DEPARTMENT OF AGRICULTURE AND CIVIL WORKS ADMINISTRATION COOPERATING.

COOPERATIVE EXTENSION WORK IN AGRICULTURE AND HOME ECONOMICS
 STATE OF NORTH DAKOTA
 NORTH DAKOTA AGRICULTURAL COLLEGE
 AND
 U.S. DEPT. OF AGRICULTURE COOPERATING.
 EXT. AGRI. ENGINEER- FARGO, N.DAK.

FARM HOUSE

CALIF 34 EX. 6511-11A SHEET 1-1A

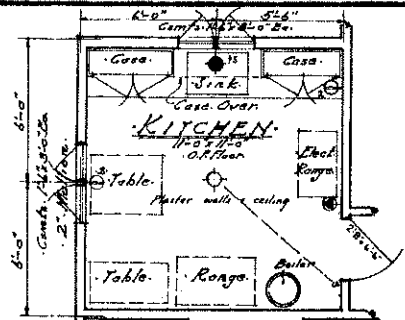

- Ceiling Outlet
- ⊙ Wall Bracket
- ⊕ Pull Switch
- ⊖ Single convenience outlet
- ⊗ Double convenience outlet
- ⊖ Power outlet
- ⊖ Switch

ELECTRIC SCHEDULE

ALTERNATE KITCHEN PLAN
Scale 1/4" = 1'-0"

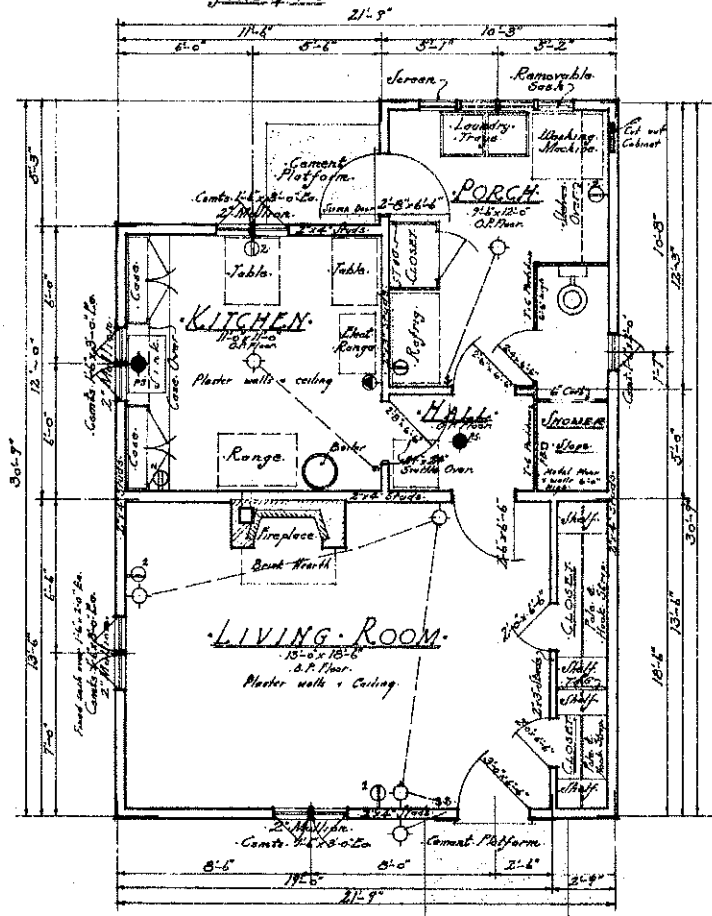

FLOOR PLAN
Scale 1/4" = 1'-0"

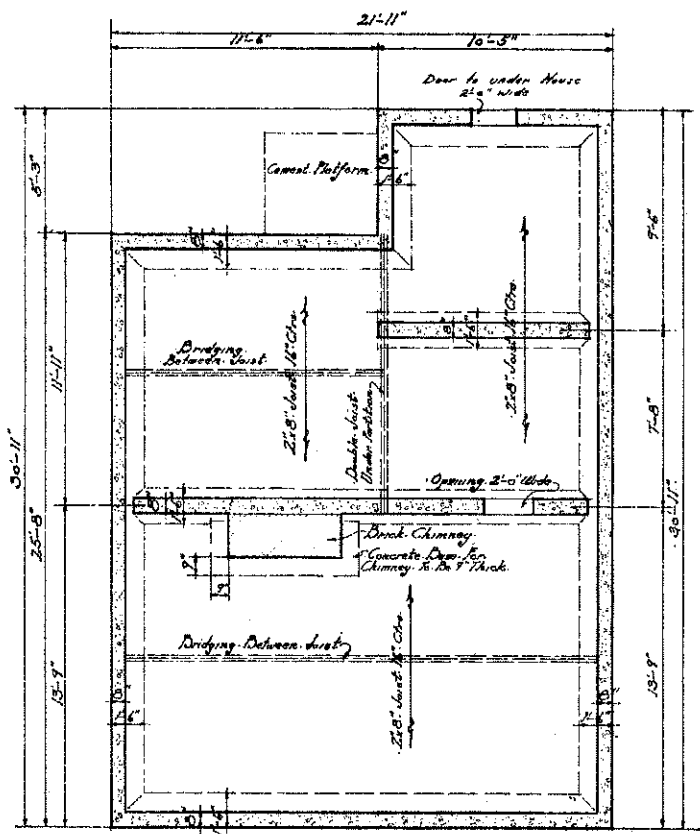

FOUNDATION PLAN
Scale 1/4" = 1'-0"

PLAN PREPARED UNDER THE RURAL HOUSING PROJECT - BUREAU OF HOME ECONOMICS AND AGRICULTURAL ENGINEERING - U.S. DEPARTMENT OF AGRICULTURE AND CIVIL WORKS ADMINISTRATION COOPERATING.

COOPERATIVE EXTENSION WORK IN AGRICULTURE AND HOME ECONOMICS
STATE OF NORTH DAKOTA
NORTH DAKOTA AGRICULTURAL COLLEGE
AND
U.S. DEPT. OF AGRICULTURE COOPERATING.
EXT. AGR'L. ENGINEER - FARGO, N. DAK.

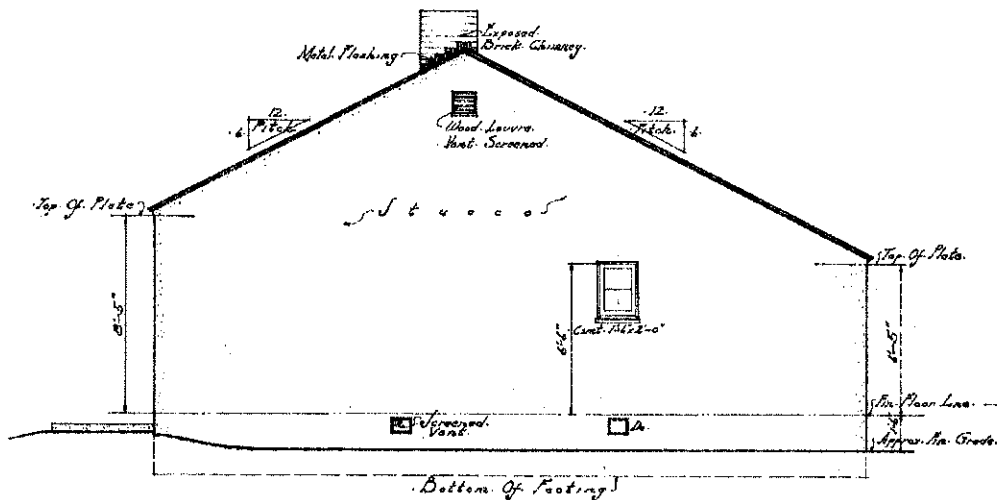

SIDE ELEVATION
Scale 1/4" = 1'-0"

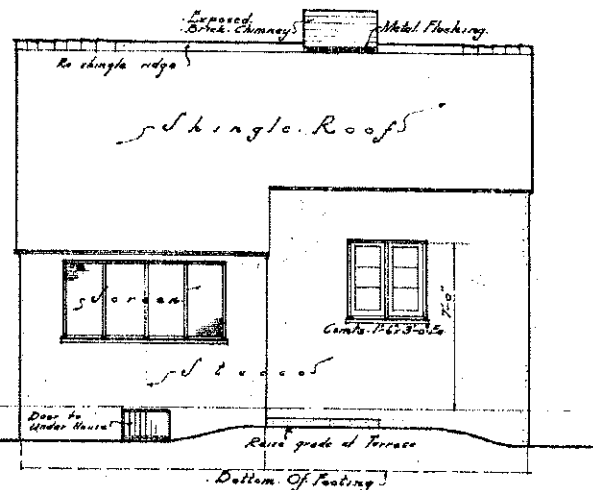

REAR ELEVATION
Scale 1/4" = 1'-0"

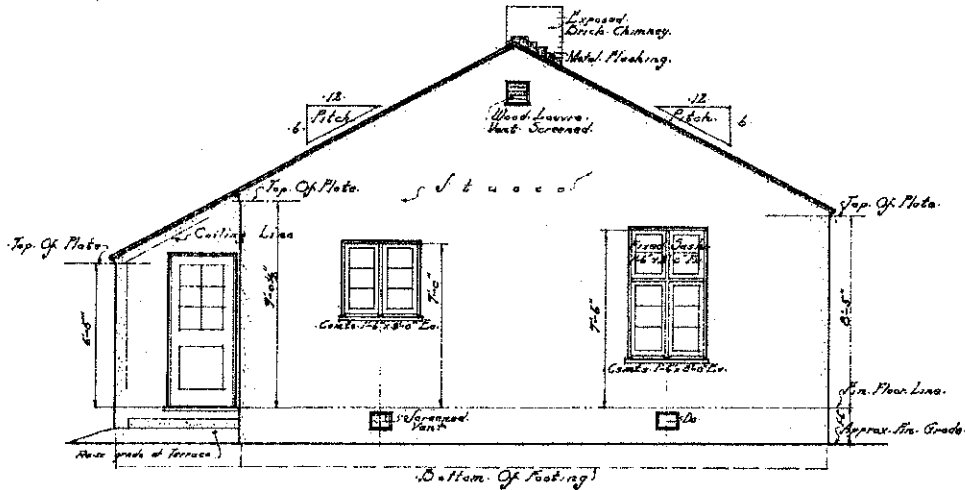

SIDE ELEVATION
Scale 1/4" = 1'-0"

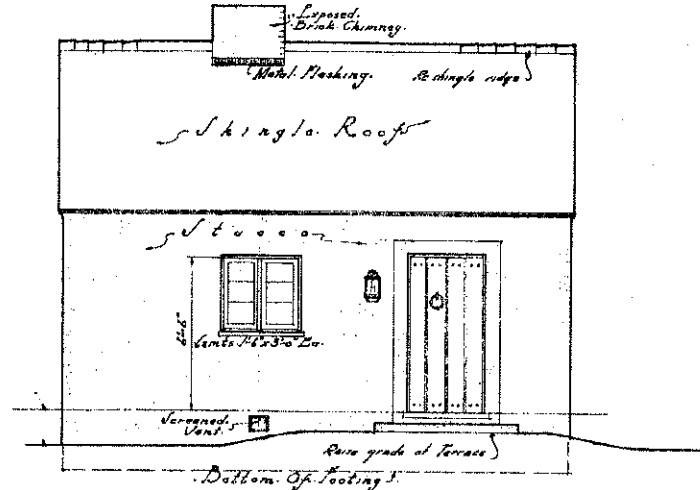

FRONT ELEVATION
Scale 1/4" = 1'-0"

COOPERATIVE EXTENSION WORK IN
 AGRICULTURE AND HOME ECONOMICS
 STATE OF NORTH DAKOTA
 NORTH DAKOTA AGRICULTURAL COLLEGE
 AND
 U.S. DEPT. OF AGRICULTURE COOPERATING.
 EXT. AGR'L. ENGINEER- FARGO, N. DAK.

FARM HOUSE

CALIF. #34 EX. 6511 SHEET 3

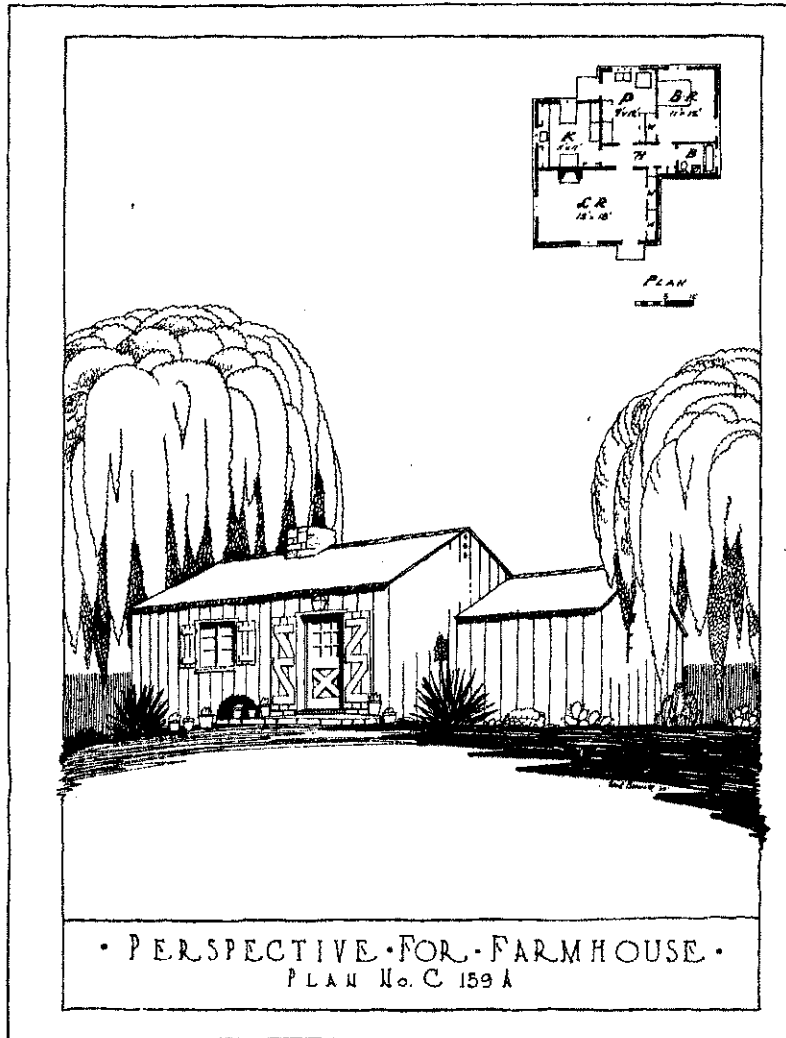

• PERSPECTIVE FOR FARMHOUSE •
PLAN No. C 159 A

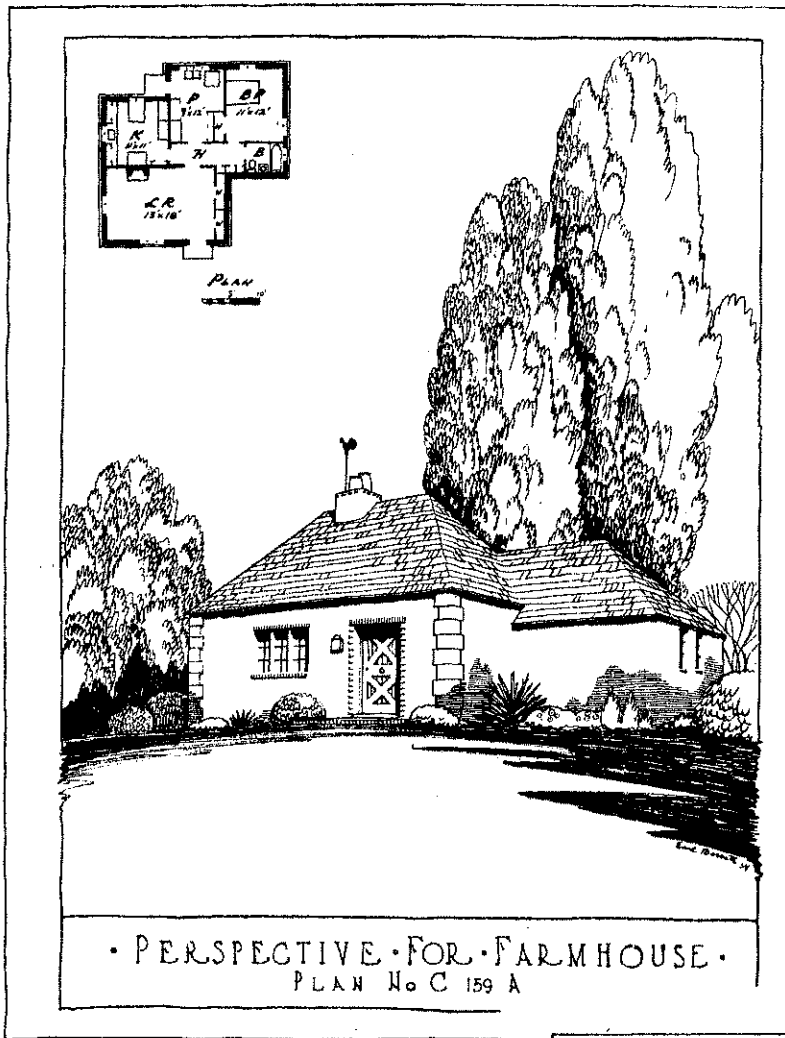

• PERSPECTIVE FOR FARMHOUSE •
PLAN No. C 159 A

PLAN PREPARED UNDER THE RURAL HOUSING PROJECT - BUREAU OF HOME ECONOMICS AND AGRICULTURAL ENGINEERING - U.S. DEPARTMENT OF AGRICULTURE AND CIVIL WORKS ADMINISTRATION COOPERATING.

COOPERATIVE EXTENSION WORK IN AGRICULTURE AND HOME ECONOMICS
STATE OF NORTH DAKOTA
NORTH DAKOTA AGRICULTURAL COLLEGE
AND
U.S. DEPT. OF AGRICULTURE COOPERATING.
EXT. AGR. ENGINEER - FARGO, N. DAK.

FARM HOUSE
CALIF. 734 EX 6511A SHEET 2A

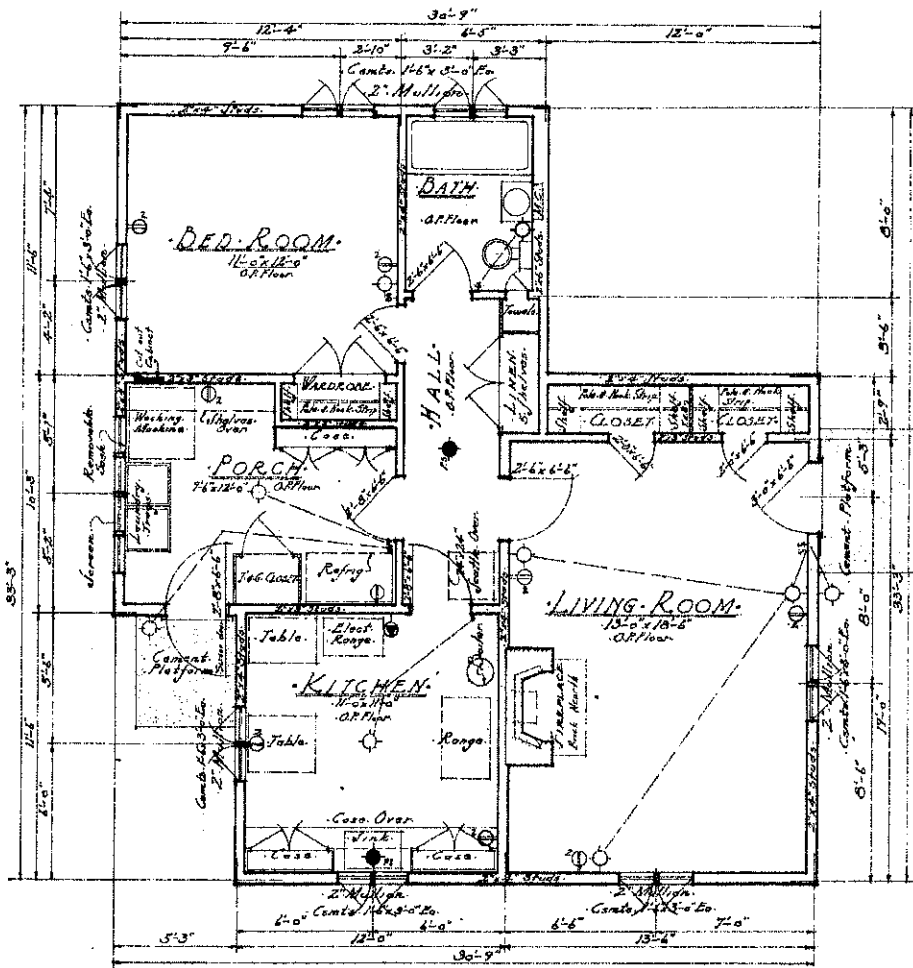

FLOOR PLAN
Scale 1/4" = 1'-0"

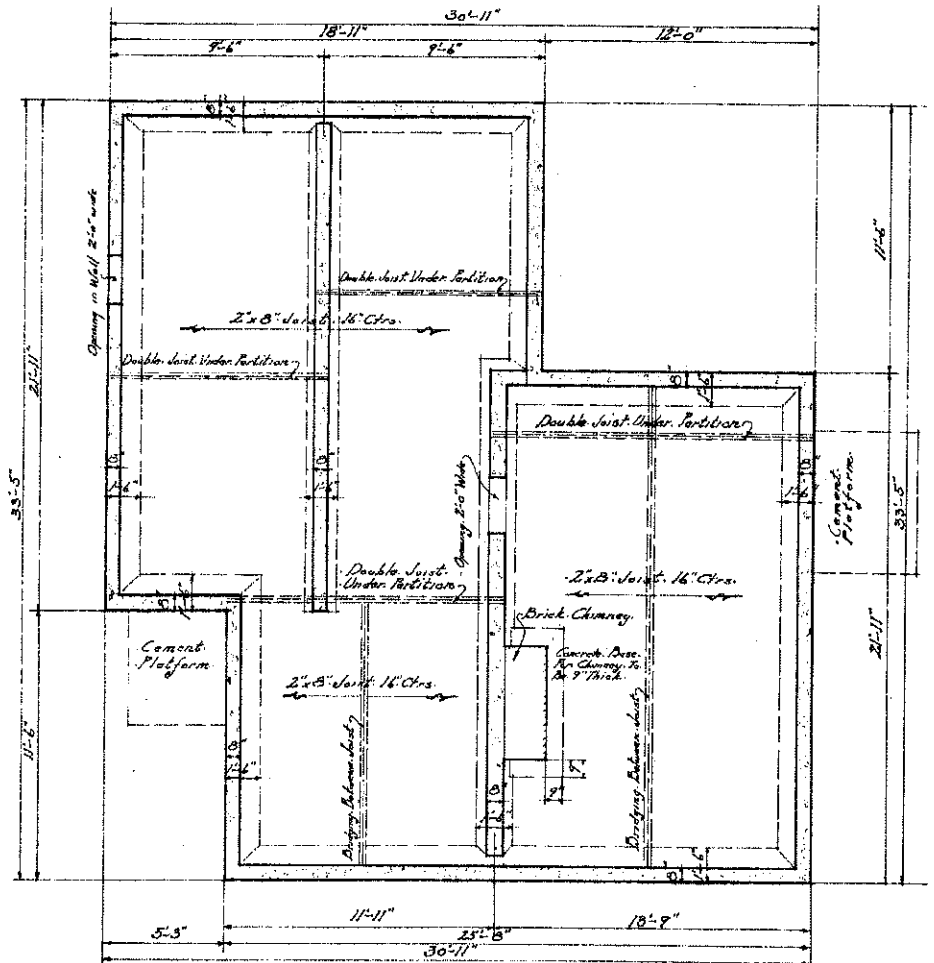

FOUNDATION PLAN
Scale 1/4" = 1'-0"

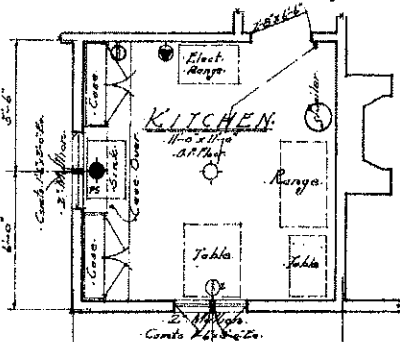

ALTERNATE KITCHEN PLAN
Scale 1/4" = 1'-0"

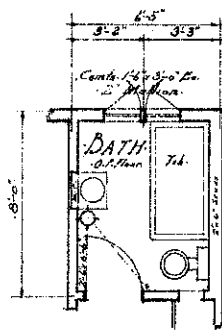

ALTERNATE BATH PLAN
Scale 1/4" = 1'-0"

- Ceiling outlet
- Wall Bracket
- Pull Switch
- ⊙ Single Convenience outlet
- ⊕ Double Convenience outlet
- ⊖ Power outlet
- ⊗ Switch

ELECTRIC SCHEDULE

PLAN PREPARED UNDER THE RURAL HOUSING PROJECT - BUREAUS OF HOME ECONOMICS AND AGRICULTURAL ENGINEERING - U.S. DEPARTMENT OF AGRICULTURE AND CIVIL WORKS ADMINISTRATION COOPERATING.

COOPERATIVE EXTENSION WORK IN AGRICULTURE AND HOME ECONOMICS
STATE OF NORTH DAKOTA
NORTH DAKOTA AGRICULTURAL COLLEGE
AND
U.S. DEPT. OF AGRICULTURE COOPERATING.
EXT. AGR'L. ENGINEER - FARBO, N. DAK.

FARM HOUSE

CALIF. '34 EX 6511 A SHEET 3A

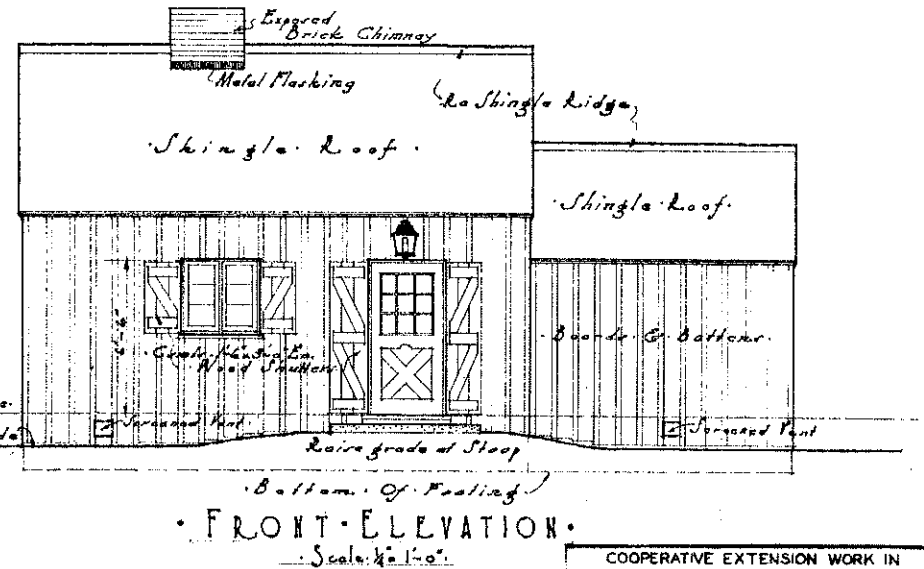
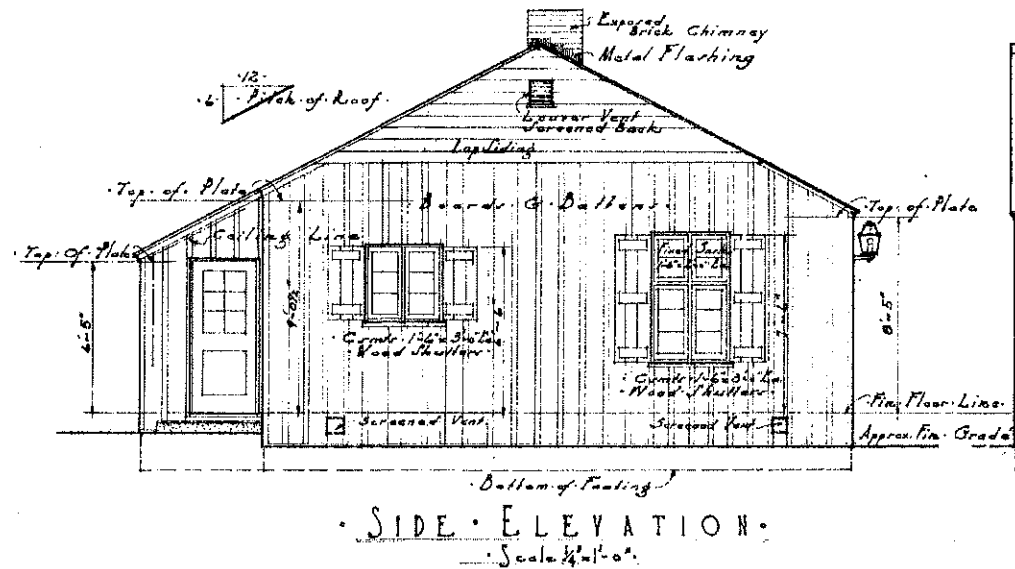
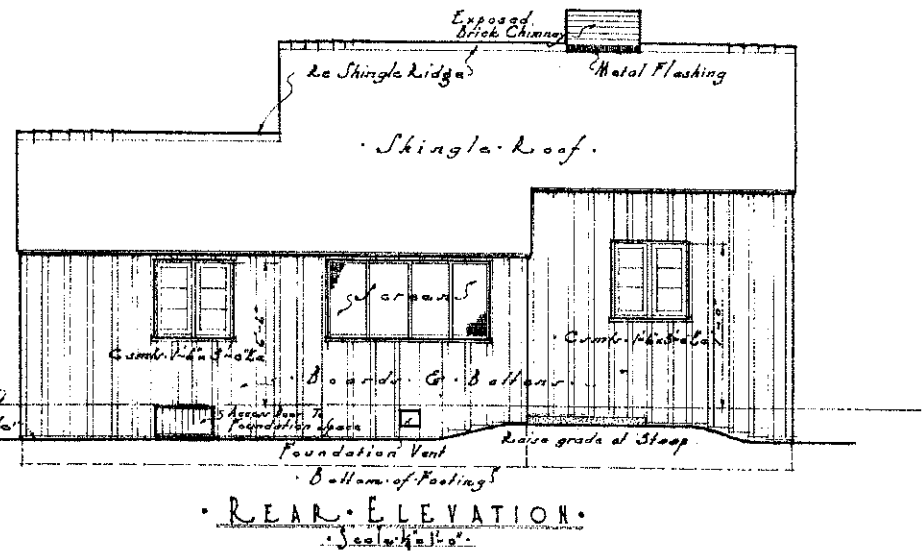
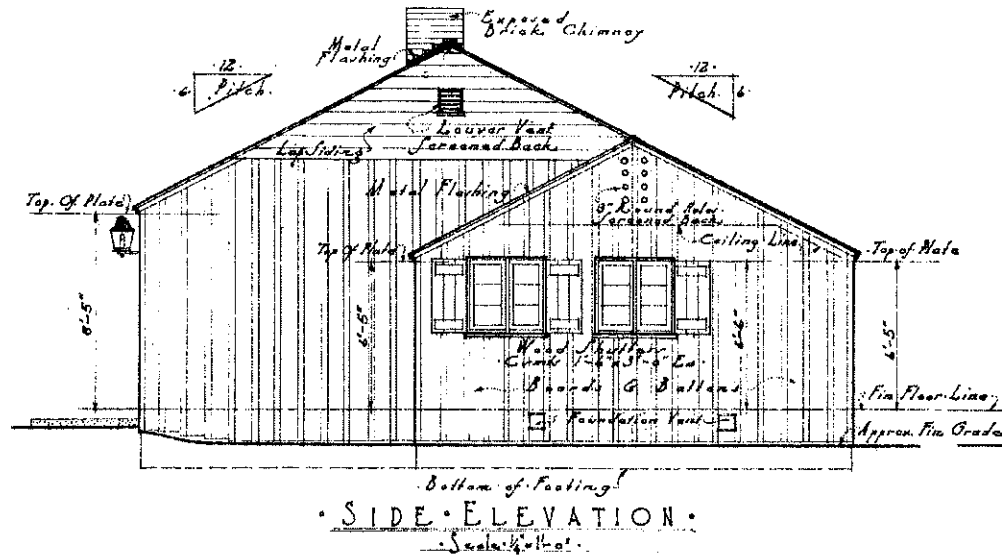

COOPERATIVE EXTENSION WORK IN
 AGRICULTURE AND HOME ECONOMICS
 STATE OF NORTH DAKOTA
 NORTH DAKOTA AGRICULTURAL COLLEGE
 AND
 U.S. DEPT. OF AGRICULTURE COOPERATING.
 EXT. AGR'L. ENGINEER—FARGO, N. DAK.

FARM HOUSE

CALIF 734 EX. 6511-A SHEET 4-A

PLAN PREPARED UNDER THE RURAL HOUSING
 PROJECT - BUREAUS OF HOME ECONOMICS AND
 AGRICULTURAL ENGINEERING - U.S. DEPARTMENT
 OF AGRICULTURE AND CIVIL WORKS
 ADMINISTRATION COOPERATING.

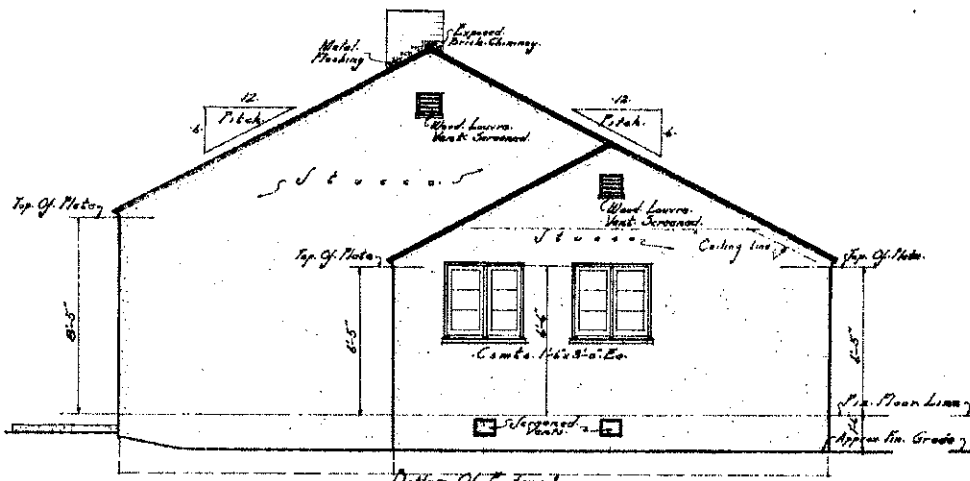

SIDE ELEVATION
Scale 1/4" = 1'-0"

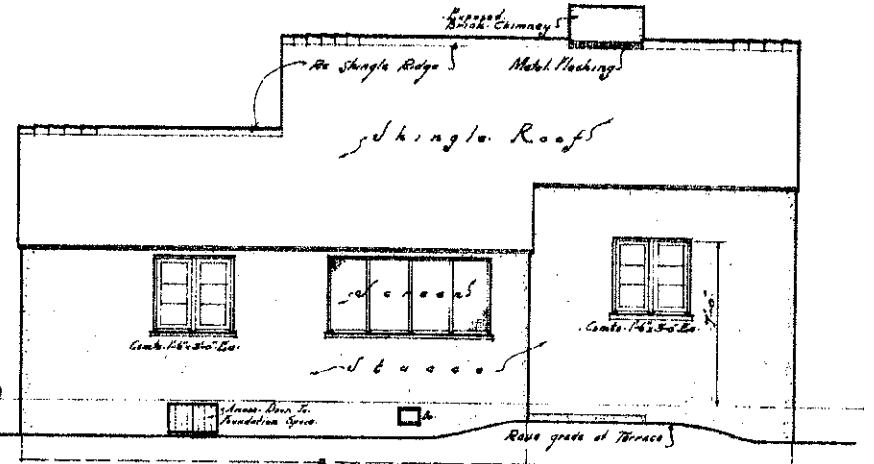

REAR ELEVATION
Scale 1/4" = 1'-0"

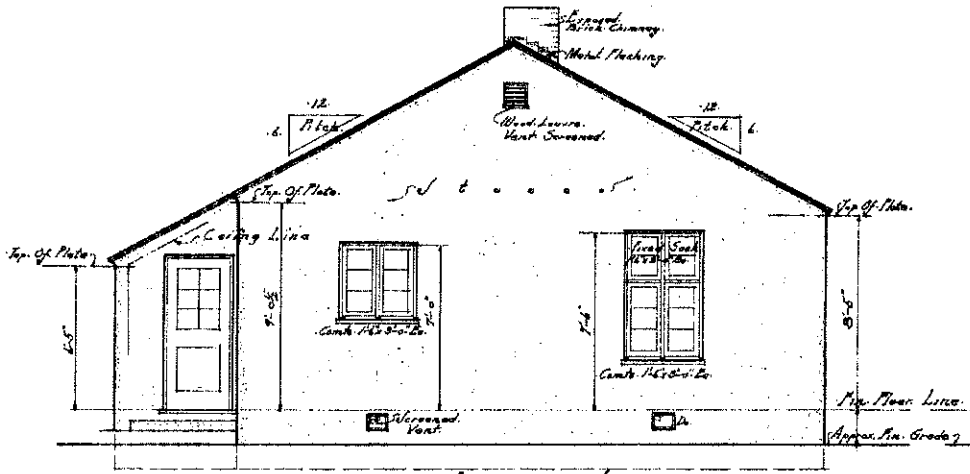

SIDE ELEVATION
Scale 1/4" = 1'-0"

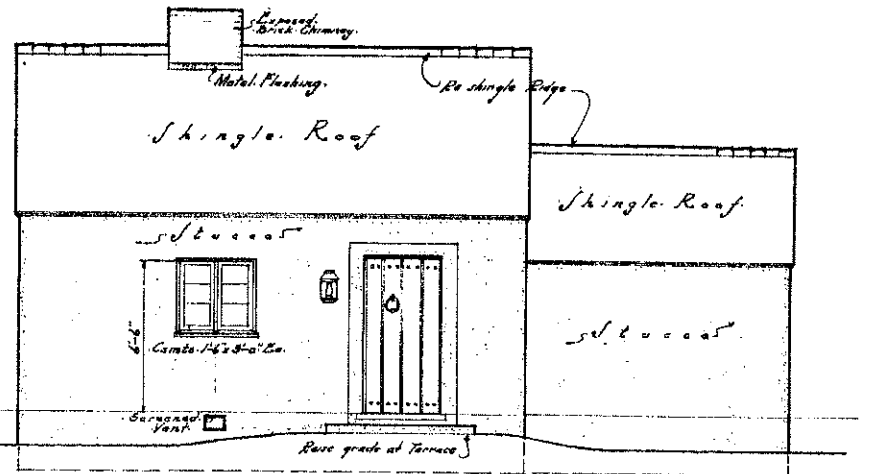

FRONT ELEVATION
Scale 1/4" = 1'-0"

PLAN PREPARED UNDER THE RURAL HOUSING PROJECT - BUREAUS OF HOME ECONOMICS AND AGRICULTURAL ENGINEERING - U.S. DEPARTMENT OF AGRICULTURE AND CIVIL WORKS ADMINISTRATION COOPERATING.

COOPERATIVE EXTENSION WORK IN
AGRICULTURE AND HOME ECONOMICS
STATE OF NORTH DAKOTA
NORTH DAKOTA AGRICULTURAL COLLEGE
AND
U.S. DEPT. OF AGRICULTURE COOPERATING.
EXT. AGRI. ENGINEER - FARGO, N. DAK.

FARM HOUSE

CALIF. 34 EX. 6511-A SHEET 5A

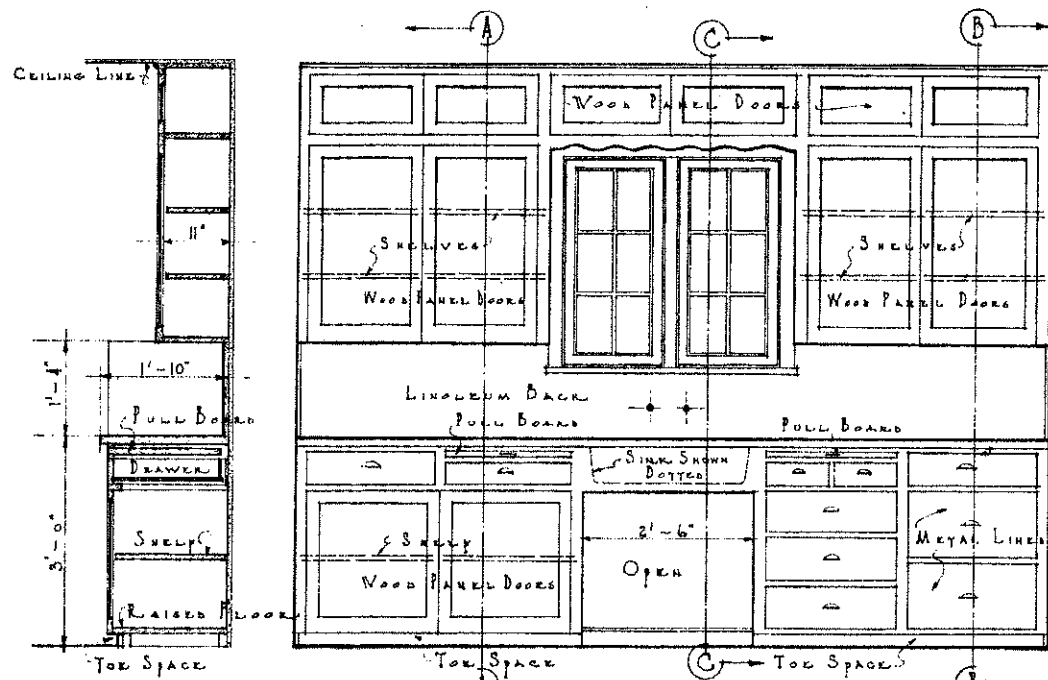

SECTION A-A • ELEVATION OF KITCHEN SHOWING CASES •

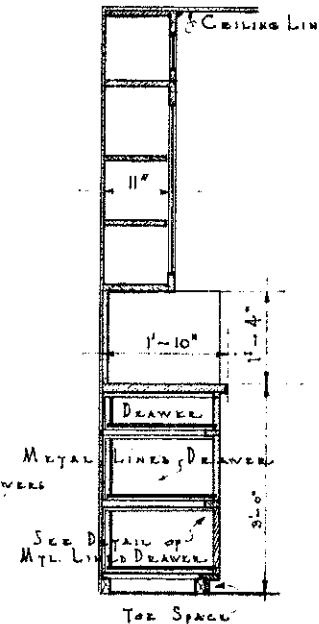

SECTION B-B

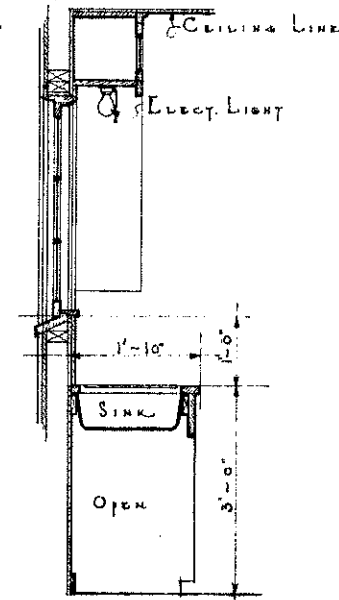

SECTION C-C

SCALE 3/4" = 1'-0"

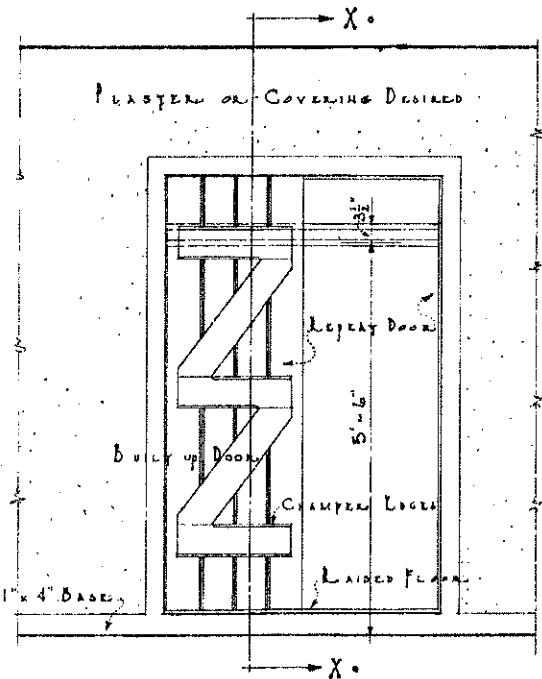

SECTION X-X • ELEVATION OF TYPICAL WARDROBE •

SCALE 3/4" = 1'-0"

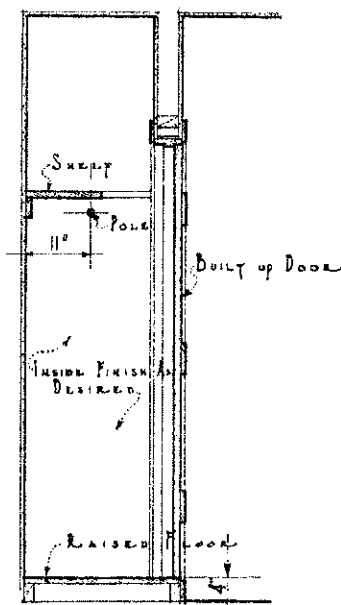

SECTION X-X

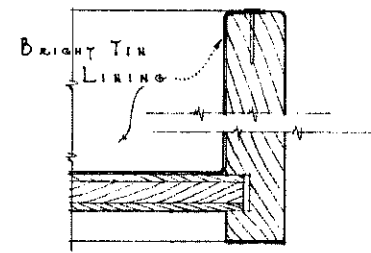

• FULL-SIZE-DETAIL • OF METAL-LINED DRAWER •

PLAN PREPARED UNDER THE RURAL HOUSING PROJECT - BUREAUS OF HOME ECONOMICS AND AGRICULTURAL ENGINEERING - U.S. DEPARTMENT OF AGRICULTURE AND CIVIL WORKS ADMINISTRATION COOPERATING.

COOPERATIVE EXTENSION WORK IN AGRICULTURE AND HOME ECONOMICS STATE OF NORTH DAKOTA NORTH DAKOTA AGRICULTURAL COLLEGE AND U.S. DEPT. OF AGRICULTURE COOPERATING. EXT. AGR'L. ENGINEER - FARGO, N.DAK.

INTERIOR DETAILS

CALIF. 734 EX. 6511-11A-11B SHEET 4-6A-7B

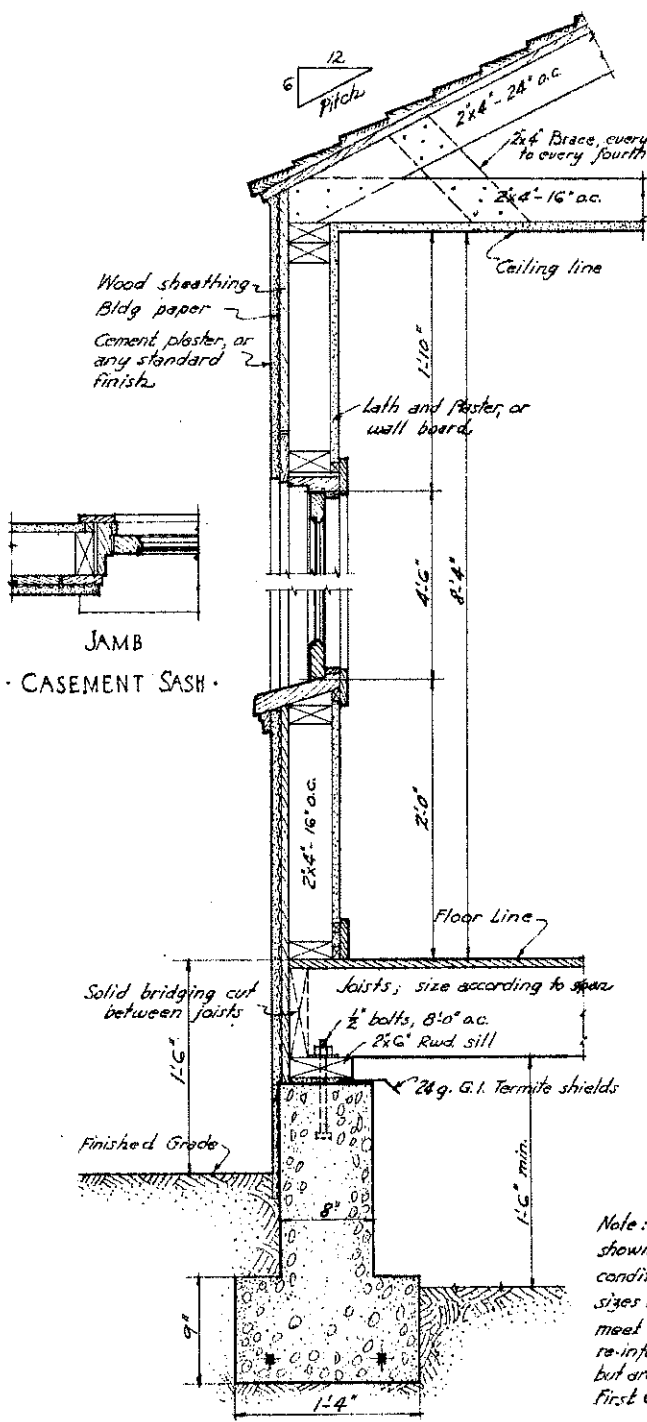

• WITH SPREAD FOOTING

Note: Size of footings as shown are for sandy loam conditions. Where necessary sizes are to be increased to meet soil conditions. The re-inforcing bars are optional, but are recommended for First Grade work.

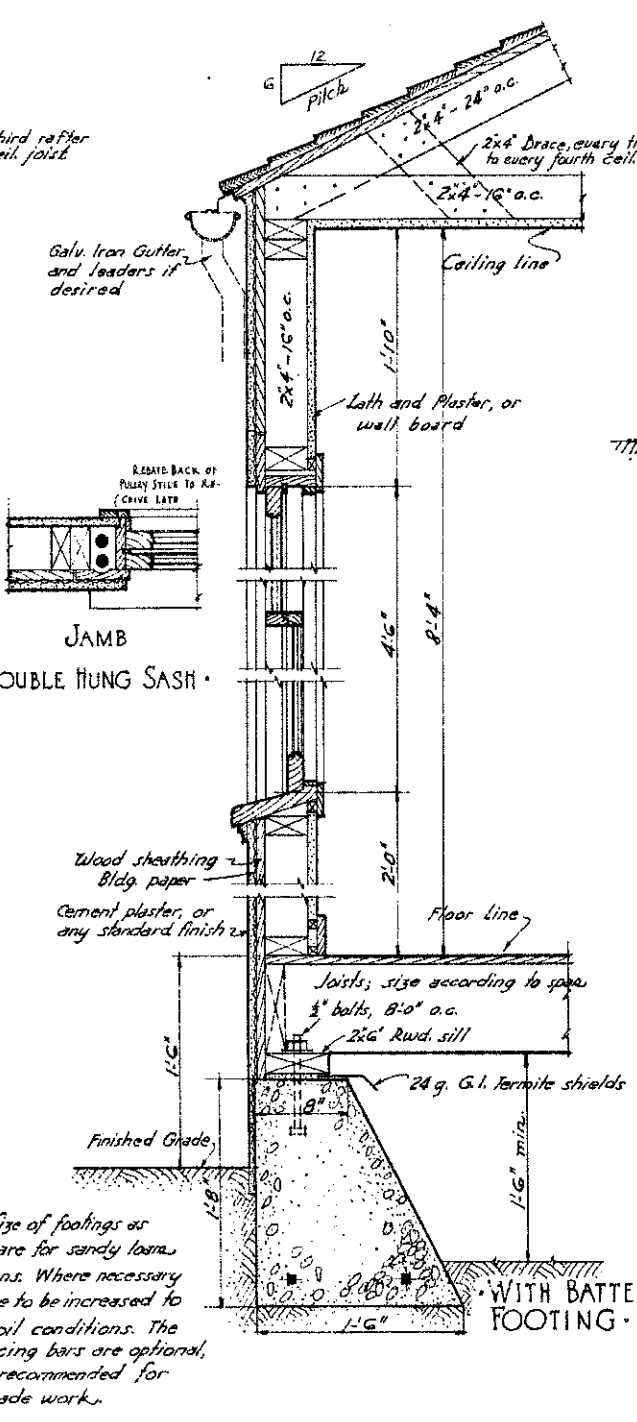

• WITH BATTER FOOTING •

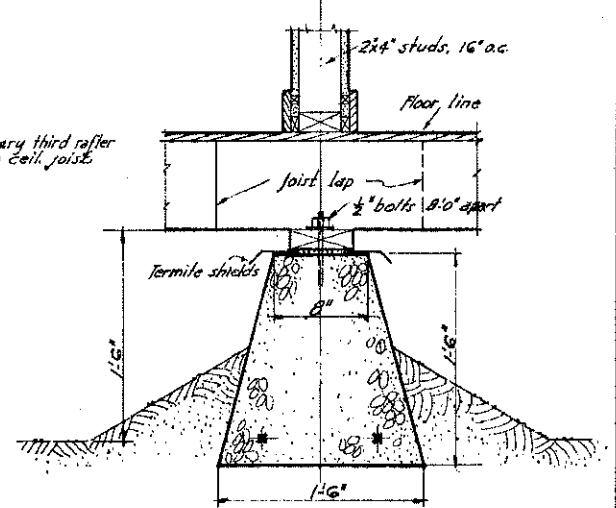

INTERIOR WALL UNDER BEARING PARTN.

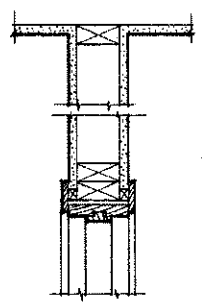

INTERIOR DOOR FRAME •

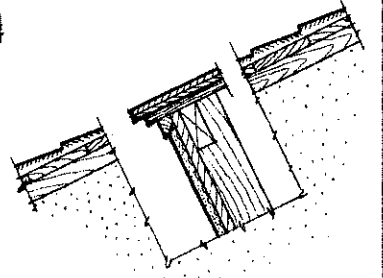

TRIM FOR GABLES •

• TYPICAL DETAILS •

PLAN PREPARED UNDER THE RURAL HOUSING PROJECT - BUREAUS OF HOME ECONOMICS AND AGRICULTURAL ENGINEERING - U.S. DEPARTMENT OF AGRICULTURE AND CIVIL WORKS ADMINISTRATION COOPERATING.

COOPERATIVE EXTENSION WORK IN AGRICULTURE AND HOME ECONOMICS STATE OF NORTH DAKOTA NORTH DAKOTA AGRICULTURAL COLLEGE AND U.S. DEPT. OF AGRICULTURE COOPERATING. EXT. AGR'L. ENGINEER - FARGO, N. DAK.

TYPICAL DETAILS

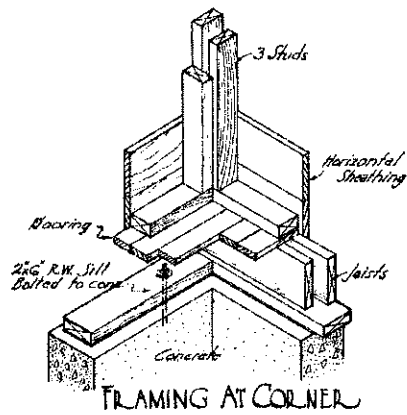

FRAMING AT CORNER

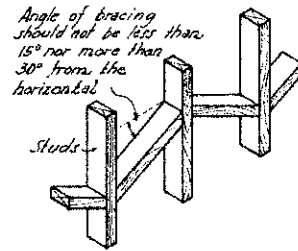

BRACING BETWEEN STUDS

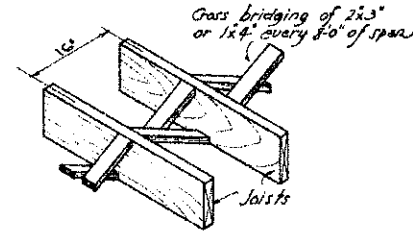

CROSS BRIDGING BET. JOISTS

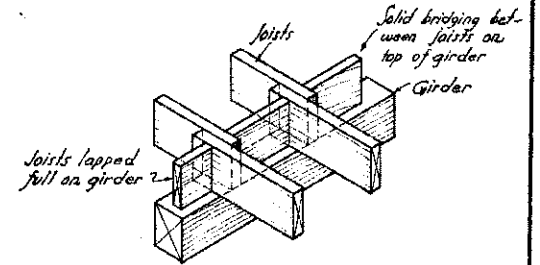

JOISTS LAPPED ON TOP OF GIRDER

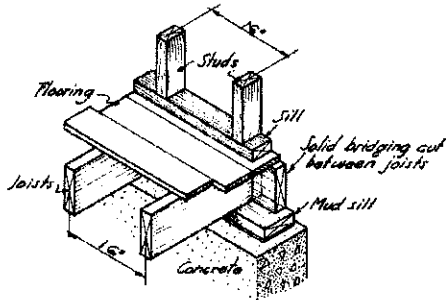

CONSTRUCTION AT SILL

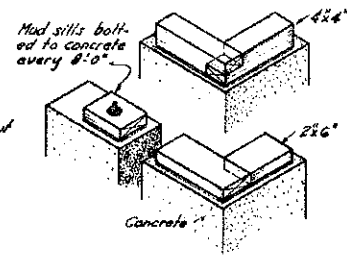

MUD SILLS AT CORNER

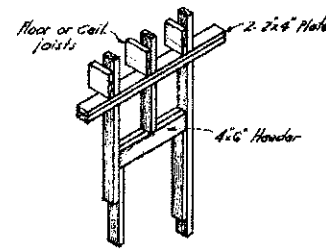

FRAMING FOR OPENINGS UNDER 3'-0" WIDE

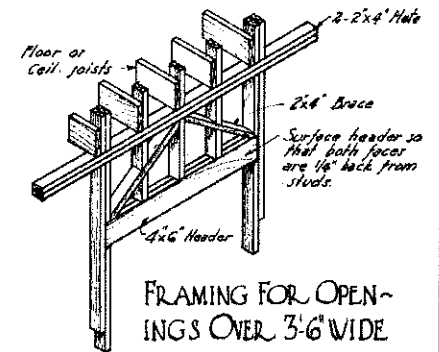

FRAMING FOR OPENINGS OVER 3'-6" WIDE

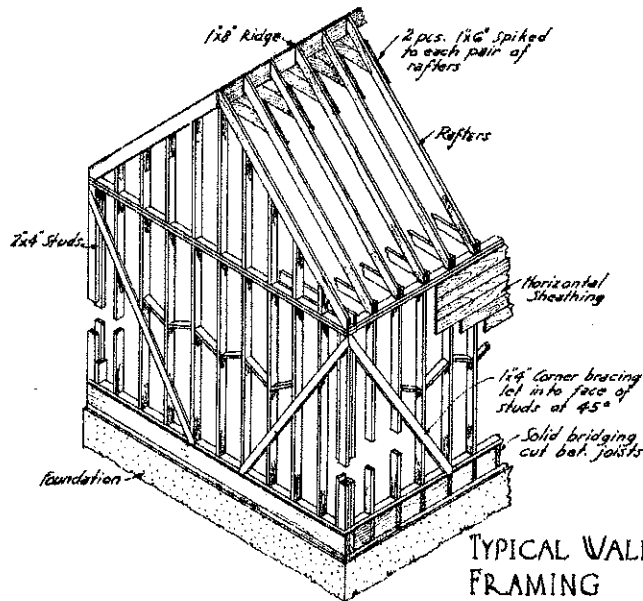

TYPICAL WALL FRAMING

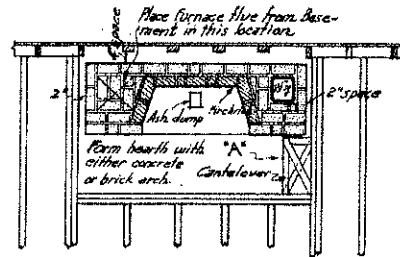

FRAMING FOR FIREPLACE

NOTE

If hearth is to be the full width of mantel, the cantilever is to be omitted as shown above at left.

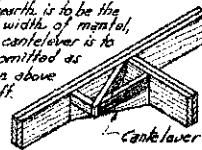

DETAIL AT 'A'



CHIMNEY DETAIL

Note: This detail shows framing where fireplace and chimney are built entirely inside the wall. Where chimney is on the outside, framing is similar to that shown except for back wall.

TYPICAL FRAMING DETAILS

PLAN PREPARED UNDER THE RURAL HOUSING PROJECT - BUREAUS OF HOME ECONOMICS AND AGRICULTURAL ENGINEERING - U.S. DEPARTMENT OF AGRICULTURE AND CIVIL WORKS ADMINISTRATION COOPERATING.

COOPERATIVE EXTENSION WORK IN AGRICULTURE AND HOME ECONOMICS
STATE OF NORTH DAKOTA
NORTH DAKOTA AGRICULTURAL COLLEGE
AND
U.S. DEPT. OF AGRICULTURE COOPERATING.
EXT. AGR'L. ENGINEER - FARGO, N. DAK.

TYPICAL DETAILS

CALIF. 734 EX. 6511-11A-11B SHEET 6-RA-98

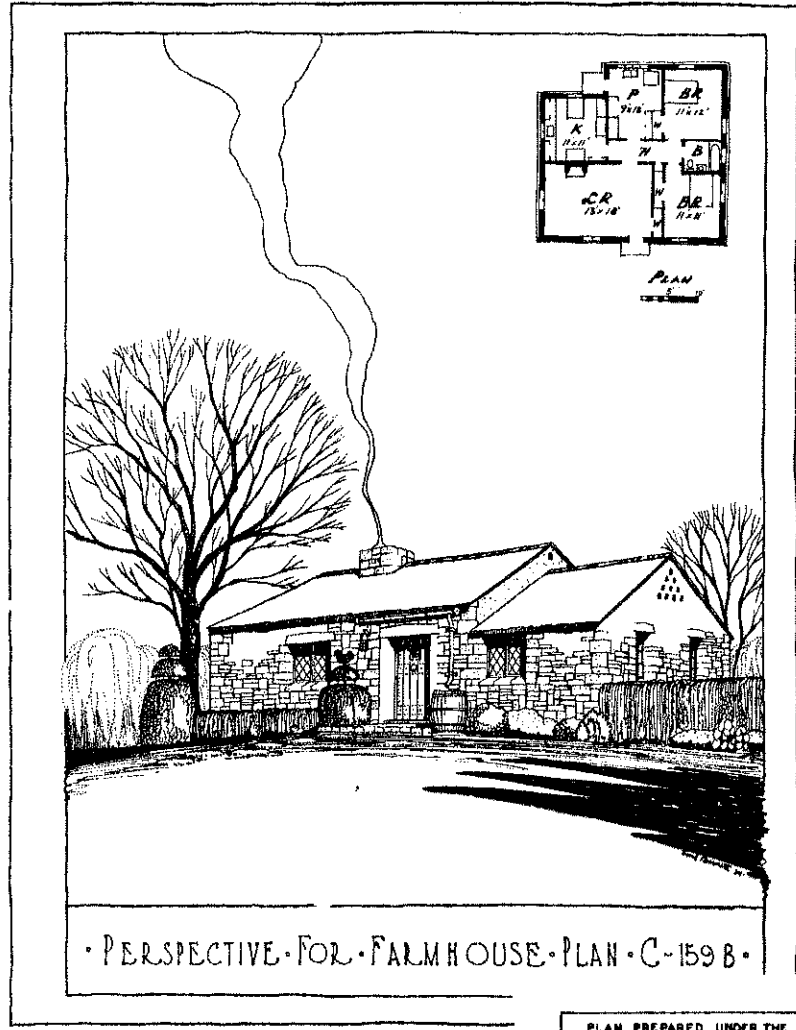
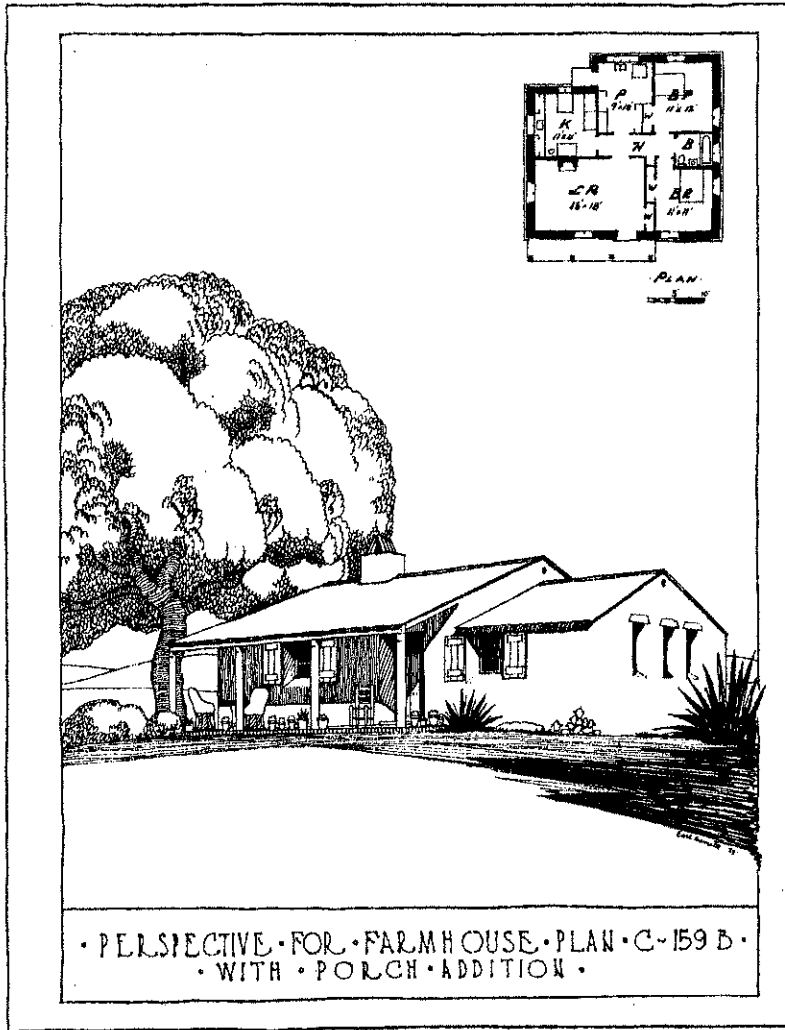

- ALTERNATE PERSPECTIVES -

PLAN PREPARED UNDER THE RURAL HOUSING PROJECT - BUREAUS OF HOME ECONOMICS AND AGRICULTURAL ENGINEERING - U.S. DEPARTMENT OF AGRICULTURE AND CIVIL WORKS ADMINISTRATION COOPERATING.

COOPERATIVE EXTENSION WORK IN AGRICULTURE AND HOME ECONOMICS
STATE OF NORTH DAKOTA
NORTH DAKOTA AGRICULTURAL COLLEGE
AND
U.S. DEPT. OF AGRICULTURE COOPERATING.
EXT. AGR'L. ENGINEER - FARGO, N. DAK.

FARM HOUSE

CALIF. 734 | EX 6511 B | SHEET 1 B

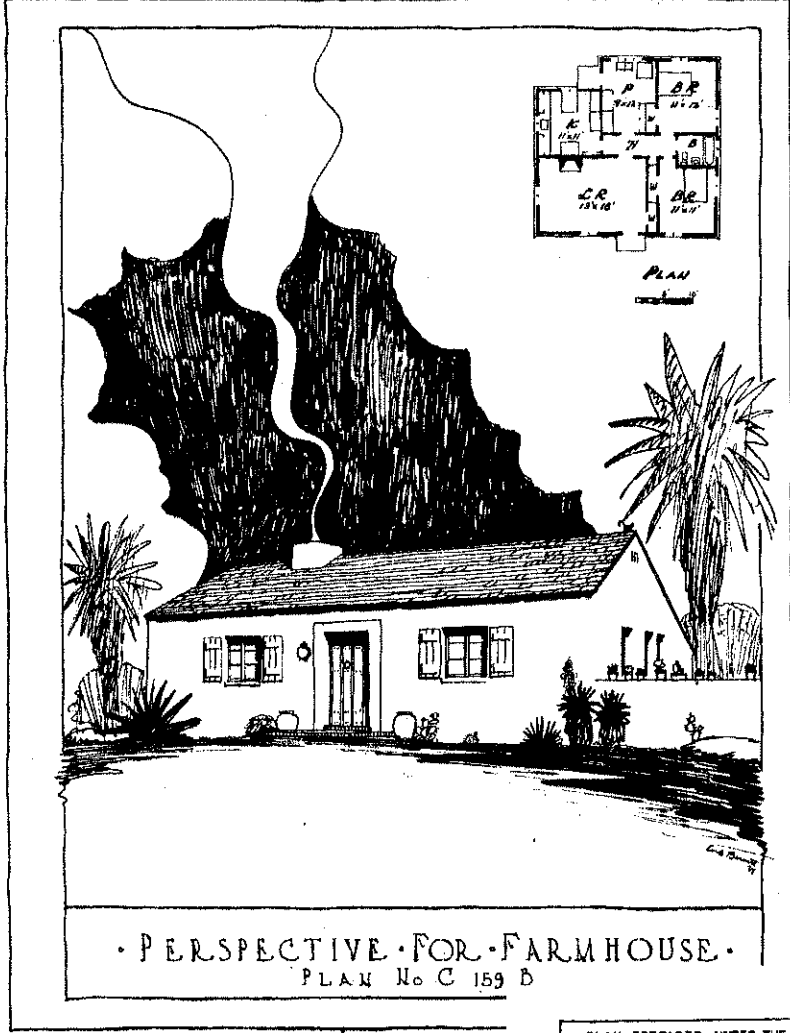
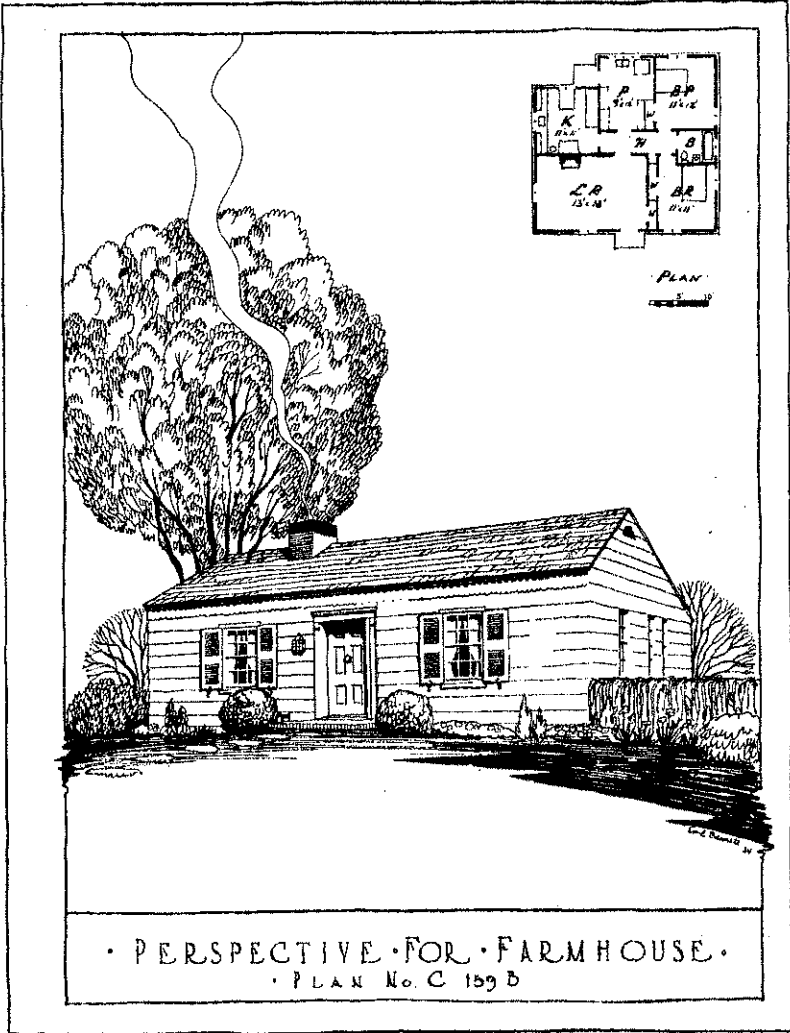

PLAN PREPARED UNDER THE RURAL HOUSING PROJECT - BUREAUS OF HOME ECONOMICS AND AGRICULTURAL ENGINEERING - U.S. DEPARTMENT OF AGRICULTURE AND CIVIL WORKS ADMINISTRATION COOPERATING.

COOPERATIVE EXTENSION WORK IN AGRICULTURE AND HOME ECONOMICS
STATE OF NORTH DAKOTA
NORTH DAKOTA AGRICULTURAL COLLEGE
AND
U.S. DEPT. OF AGRICULTURE COOPERATING.
EXT. AGR'L. ENGINEER - FARGO, N. DAK.

FARM HOUSE

CALIF. '34 EX. 6511 B SHEET 2 B

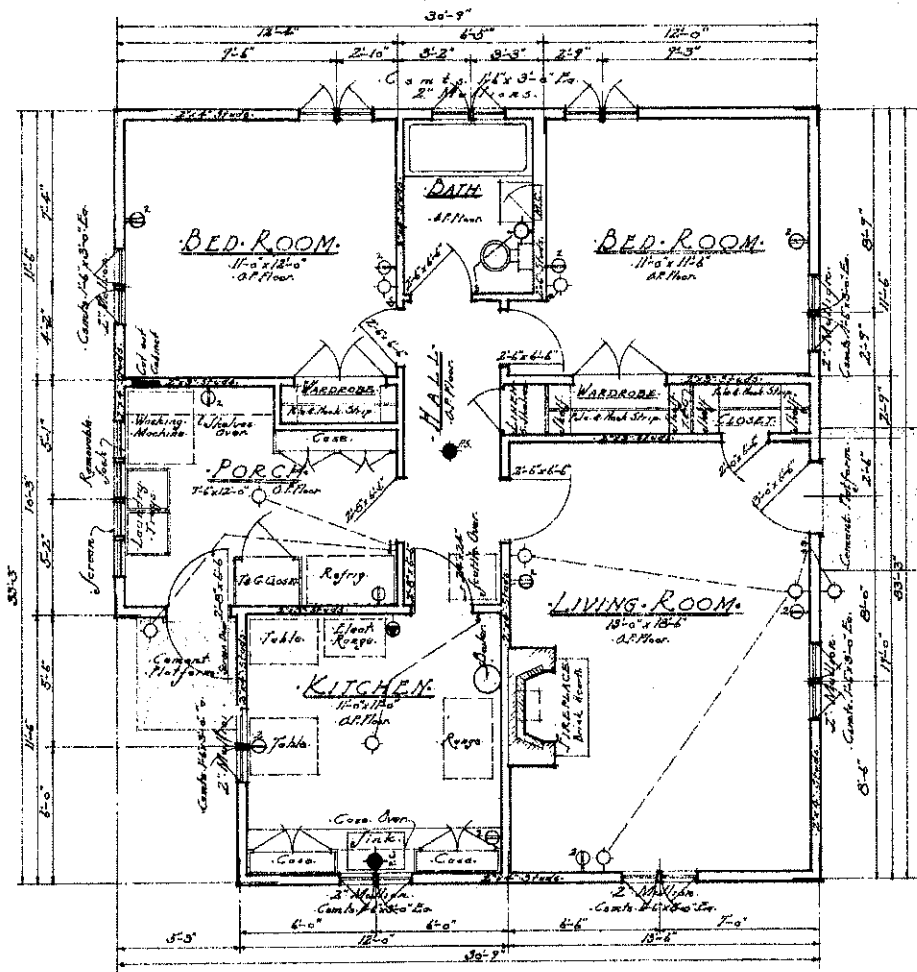

FLOOR PLAN
Scale 1/4" = 1'-0"

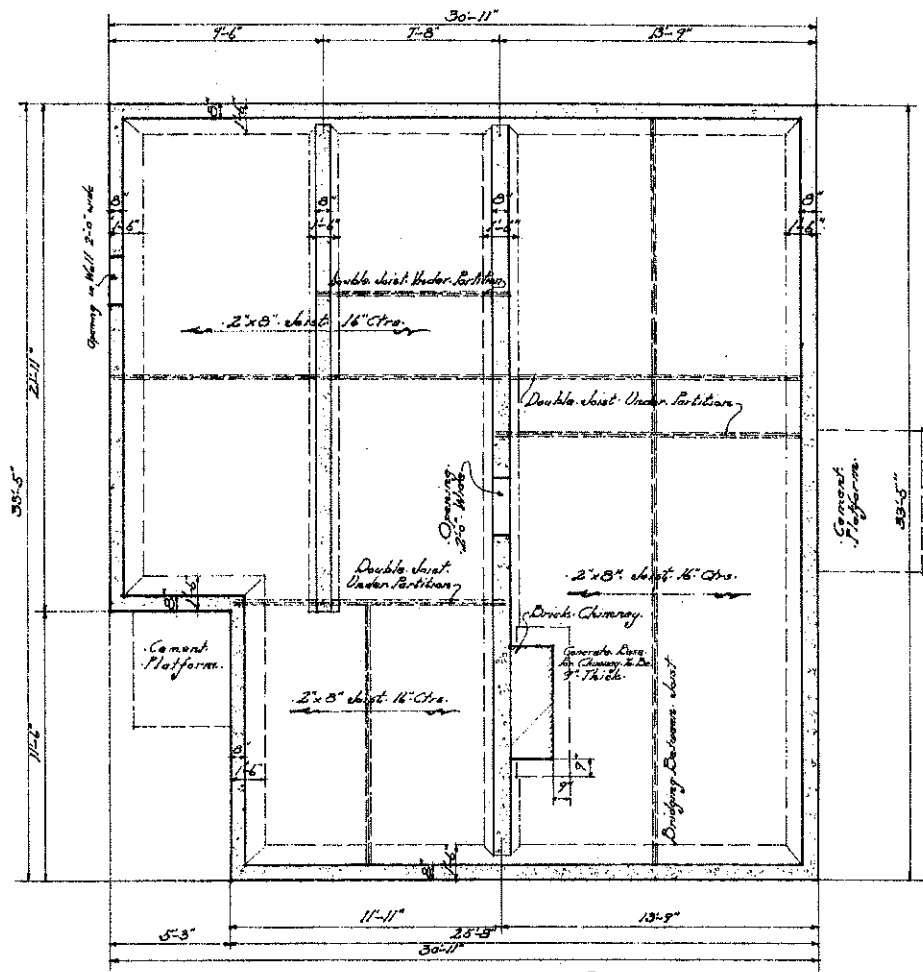

FOUNDATION PLAN
Scale 1/4" = 1'-0"

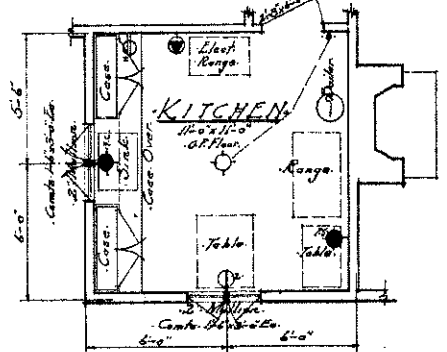

ALTERNATE KITCHEN PLAN
Scale 1/4" = 1'-0"

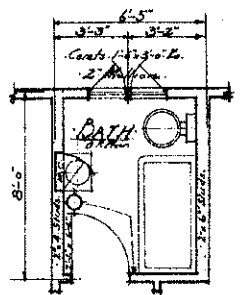

ALTERNATE BATH PLAN
Scale 1/4" = 1'-0"

- Ceiling Outlet
 - Wall Bracket
 - Pull Switch
 - Single convenience outlet
 - Double convenience outlet
 - Power Outlet
 - Switch
- ELECTRIC SCHEDULE**

PLAN PREPARED UNDER THE RURAL HOUSING PROJECT - BUREAU OF HOME ECONOMICS AND AGRICULTURAL ENGINEERING - U.S. DEPARTMENT OF AGRICULTURE AND CIVIL WORKS ADMINISTRATION COOPERATING.

COOPERATIVE EXTENSION WORK IN AGRICULTURE AND HOME ECONOMICS
STATE OF NORTH DAKOTA
NORTH DAKOTA AGRICULTURAL COLLEGE
AND
U.S. DEPT. OF AGRICULTURE COOPERATING.
EXT. AGR'L. ENGINEER - FARGO, N. DAK.

FARM HOUSE
CALIF. '34 EX. 6511 B SHEET 3B

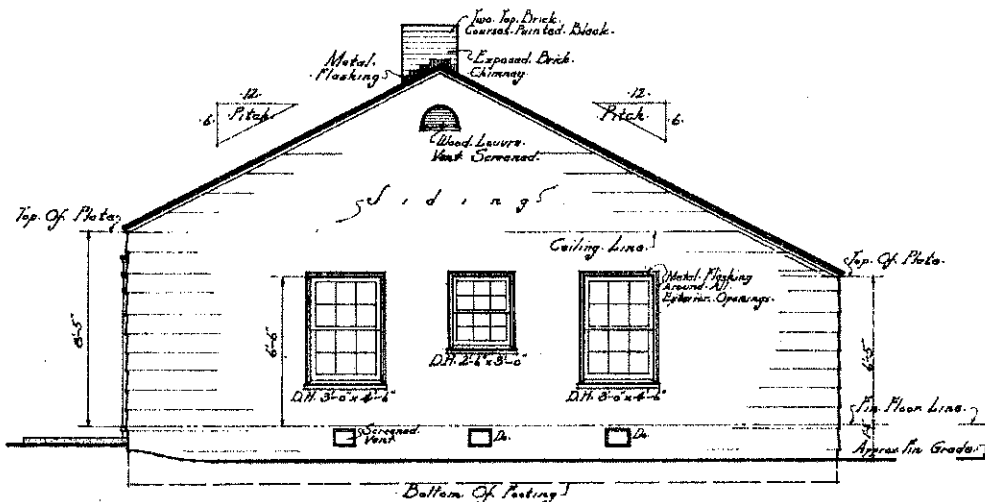

SIDE ELEVATION.
Scale 1/4" = 1'-0"

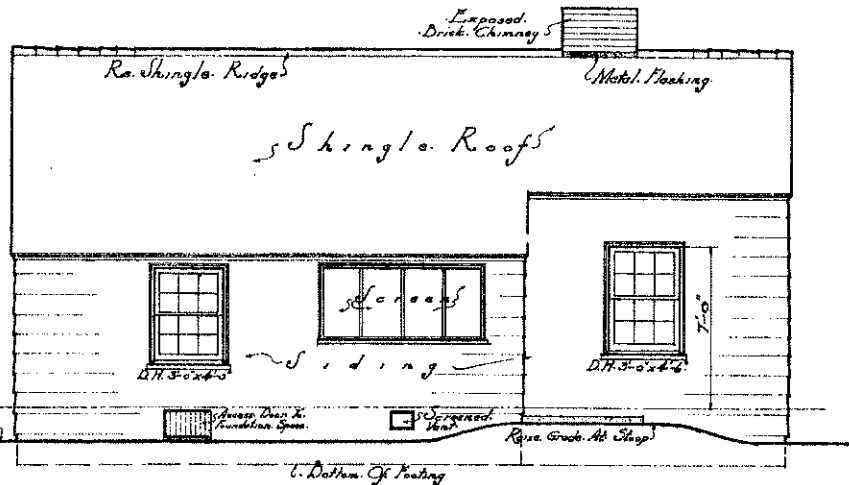

REAR ELEVATION.
Scale 1/4" = 1'-0"

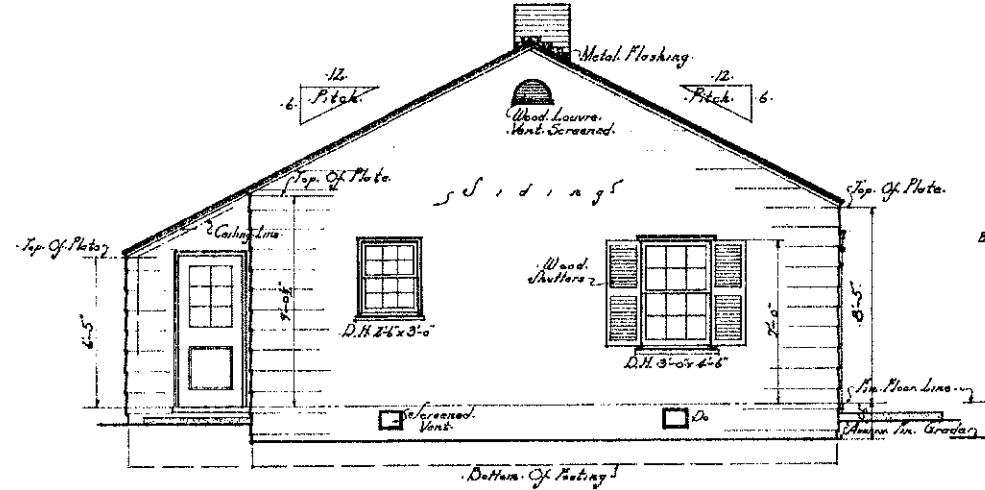

SIDE ELEVATION.
Scale 1/4" = 1'-0"

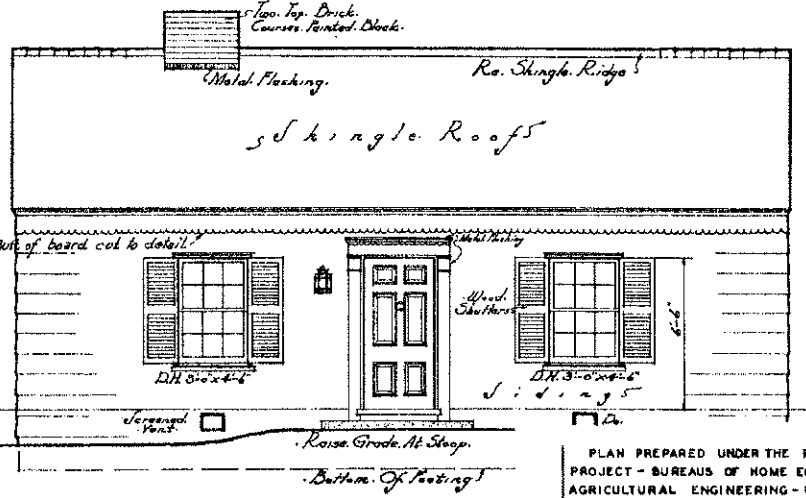

FRONT ELEVATION.
Scale 1/4" = 1'-0"

PLAN PREPARED UNDER THE RURAL HOUSING PROJECT - BUREAU OF HOME ECONOMICS AND AGRICULTURAL ENGINEERING - U.S. DEPARTMENT OF AGRICULTURE AND CIVIL WORKS ADMINISTRATION COOPERATING.

COOPERATIVE EXTENSION WORK IN AGRICULTURE AND HOME ECONOMICS STATE OF NORTH DAKOTA NORTH DAKOTA AGRICULTURAL COLLEGE AND U.S. DEPT. OF AGRICULTURE COOPERATING. EXT. AGR'L. ENGINEER - FARGO, N. DAK.

FARM HOUSE

CALIF. 34 EX. 6511 B SHEET 4B

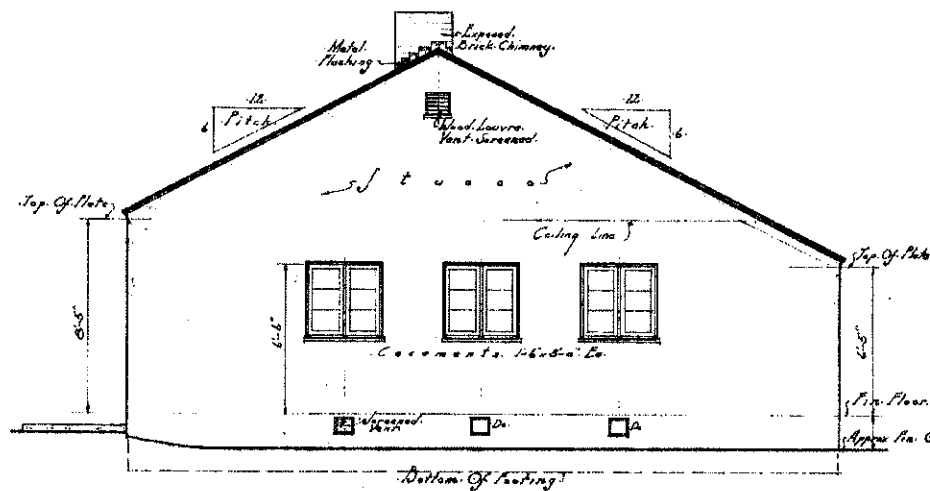

SIDE ELEVATION
Scale: 1/4" = 1'-0"

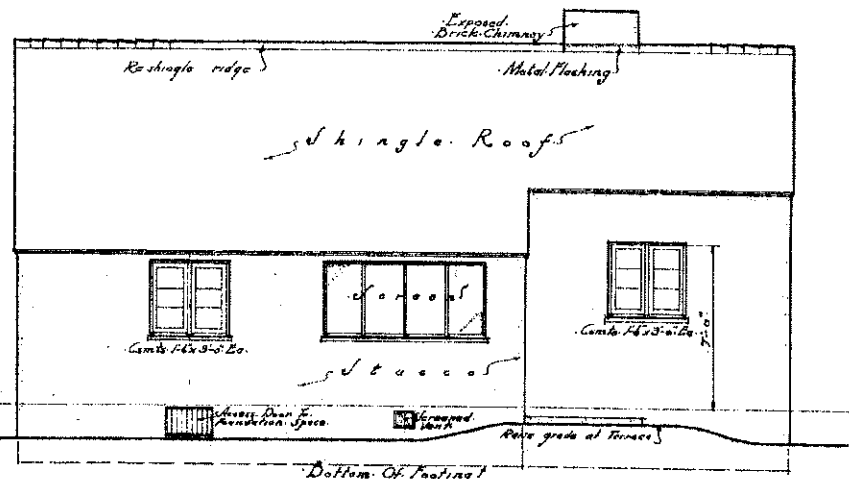

REAR ELEVATION
Scale: 1/4" = 1'-0"

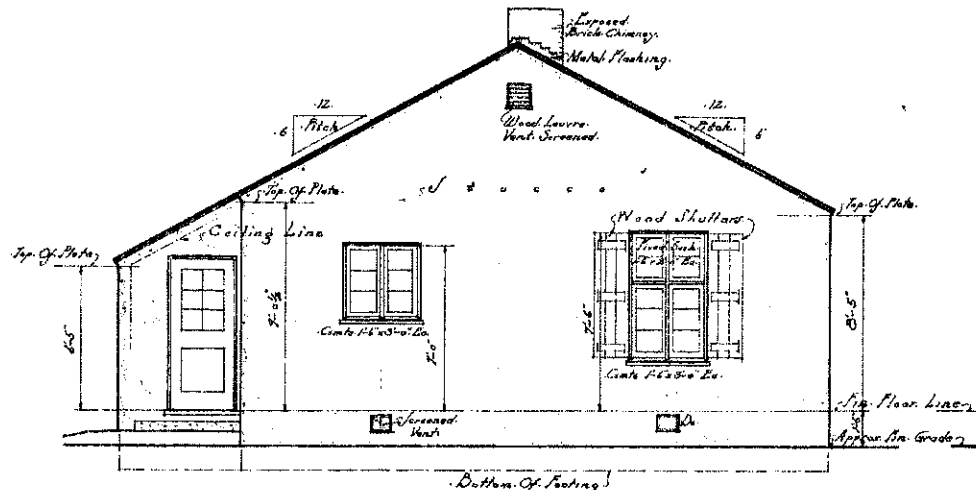

SIDE ELEVATION
Scale: 1/4" = 1'-0"

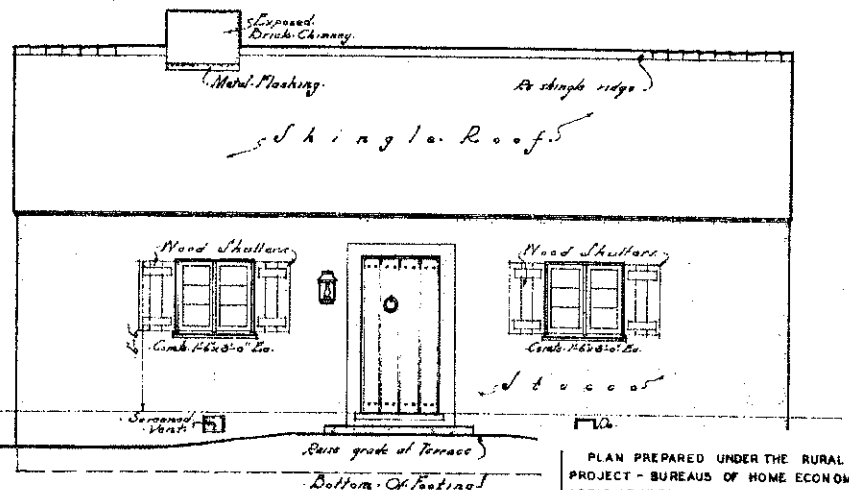

FRONT ELEVATION
Scale: 1/4" = 1'-0"

PLAN PREPARED UNDER THE RURAL HOUSING PROJECT - BUREAUS OF HOME ECONOMICS AND AGRICULTURAL ENGINEERING - U.S. DEPARTMENT OF AGRICULTURE AND CIVIL WORKS ADMINISTRATION COOPERATING.

COOPERATIVE EXTENSION WORK IN AGRICULTURE AND HOME ECONOMICS
STATE OF NORTH DAKOTA
NORTH DAKOTA AGRICULTURAL COLLEGE
AND
U.S. DEPT. OF AGRICULTURE COOPERATING.
EXT. AGRI. ENGINEER - FARGO, N. DAK.

FARM HOUSE

CALIF. 34 EX. 6511 B SHEET 5 B

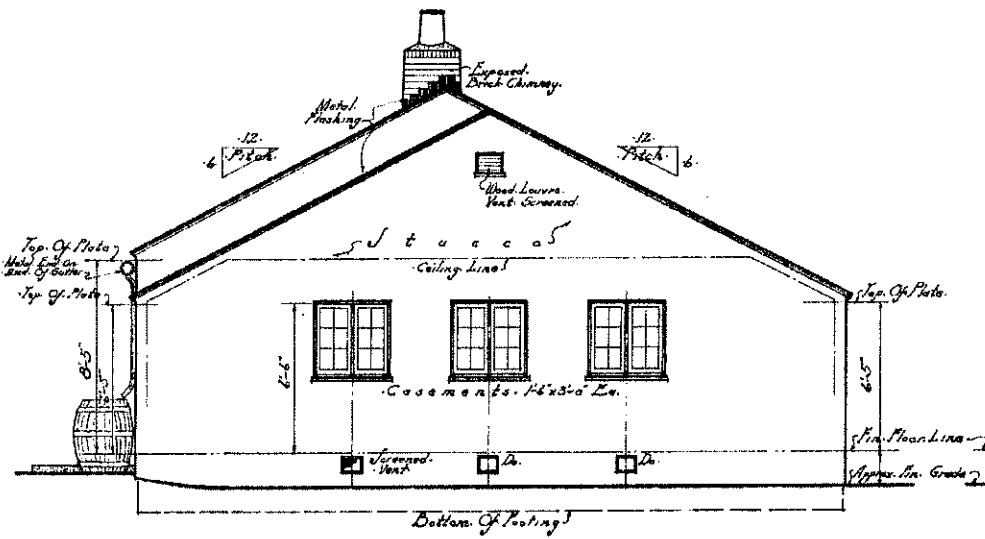

SIDE ELEVATION
Scale 1/4" = 1'-0"

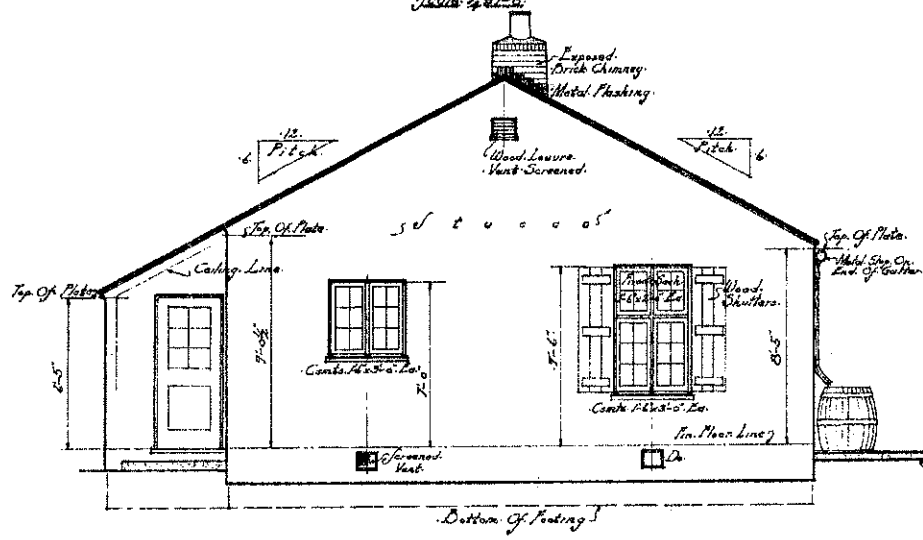

SIDE ELEVATION
Scale 1/4" = 1'-0"

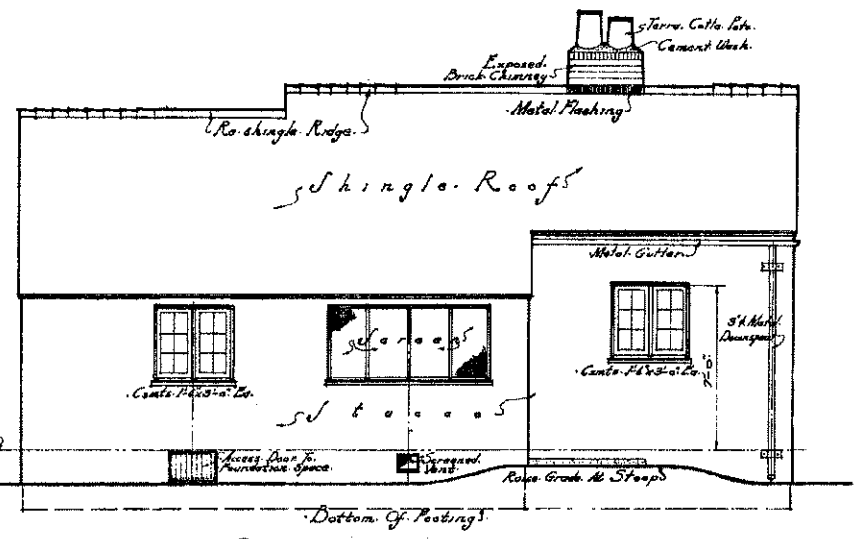

REAR ELEVATION
Scale 1/4" = 1'-0"

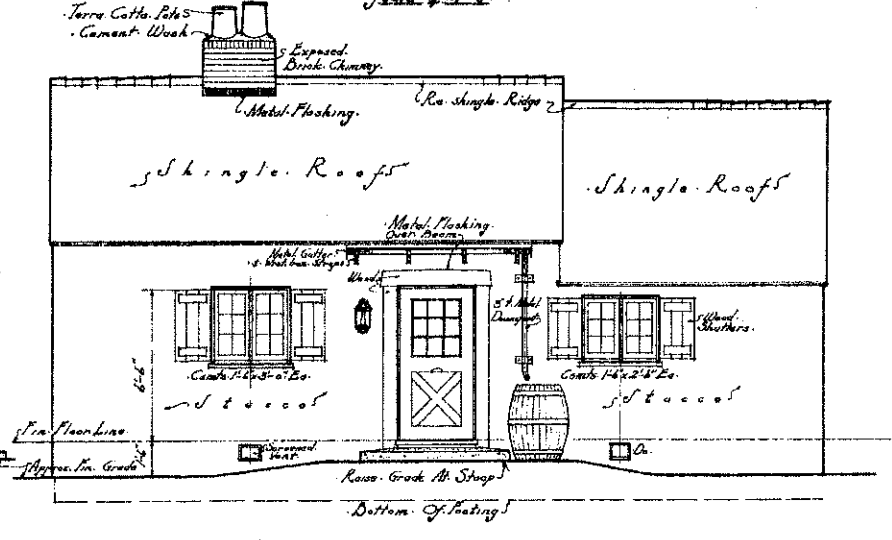

FRONT ELEVATION
Scale 1/4" = 1'-0"

PLAN PREPARED UNDER THE RURAL HOUSING PROJECT - BUREAUS OF HOME ECONOMICS AND AGRICULTURAL ENGINEERING - U.S. DEPARTMENT OF AGRICULTURE AND CIVIL WORKS ADMINISTRATION COOPERATING.

COOPERATIVE EXTENSION WORK IN AGRICULTURE AND HOME ECONOMICS
STATE OF NORTH DAKOTA
NORTH DAKOTA AGRICULTURAL COLLEGE
AND
U.S. DEPT. OF AGRICULTURE COOPERATING.
EXT. AGR'L. ENGINEER-FARGO, N.DAK.
FARM HOUSE
CALIF. '34 EX 6511-B SHEET 6B