

FOUNDATION PLAN

SCALE 0 4 8 12 FT.

HEATING SYSTEM INDICATED IS OF THE PERIMETER TYPE - SIZE OF HEATER, PLENUM, PERIMETER AND SUPPLY LINES, REGISTERS ETC., TO BE DETERMINED BY HEATING CONTRACTOR AND MANUFACTURERS RECOMMENDATIONS FOR UNIT TO BE INSTALLED. -R ON PLAN ABOVE INDICATES APPROXIMATE LOCATION OF REGISTERS ON FIRST FLOOR. -R-1 IS REGISTER UNDER COUNTER IN KITCHEN.

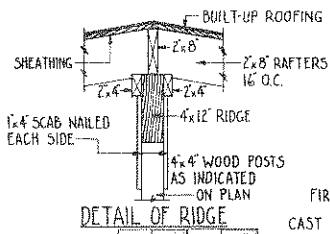

DETAIL OF RIDGE

SCALE 0 1 2 FT.

FOOTING REINFORCEMENT AT BEARING POINTS OF POSTS IN WALLS AND PARTITIONS AS INDICATED ON FIRST FLOOR PLAN

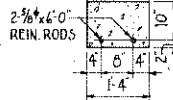

SECTION

SCALE 0 1 2 3 FT.

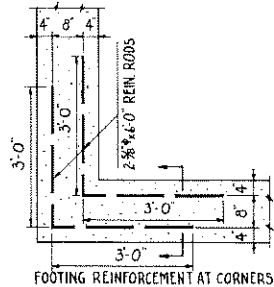

FOOTING REINFORCEMENT AT CORNERS

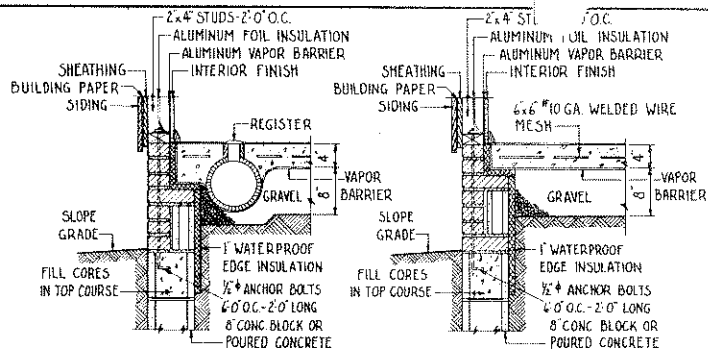

TYPICAL DETAIL OF PERIMETER HEATING LINE

ALTERNATE DETAIL IF PERIMETER HEATING SYSTEM IS NOT USED

SCALE 0 1 2 FT.

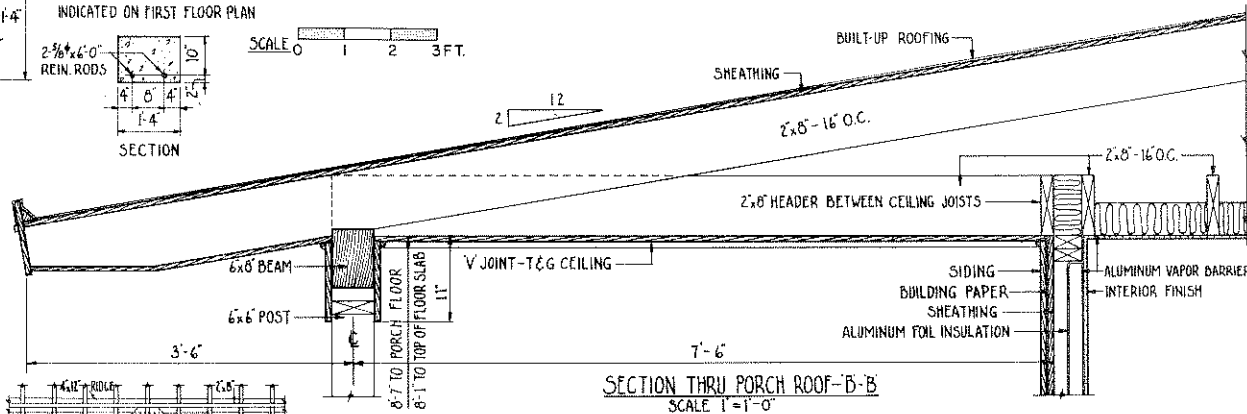

SECTION THRU PORCH ROOF-B-B

SCALE 1"=1'-0"

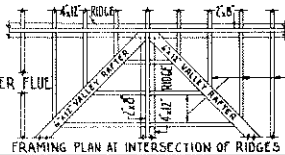

FRAMING PLAN AT INTERSECTION OF RIDGES

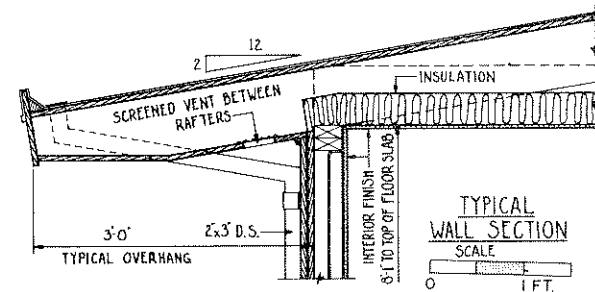

TYPICAL WALL SECTION

SCALE 0 1 FT.

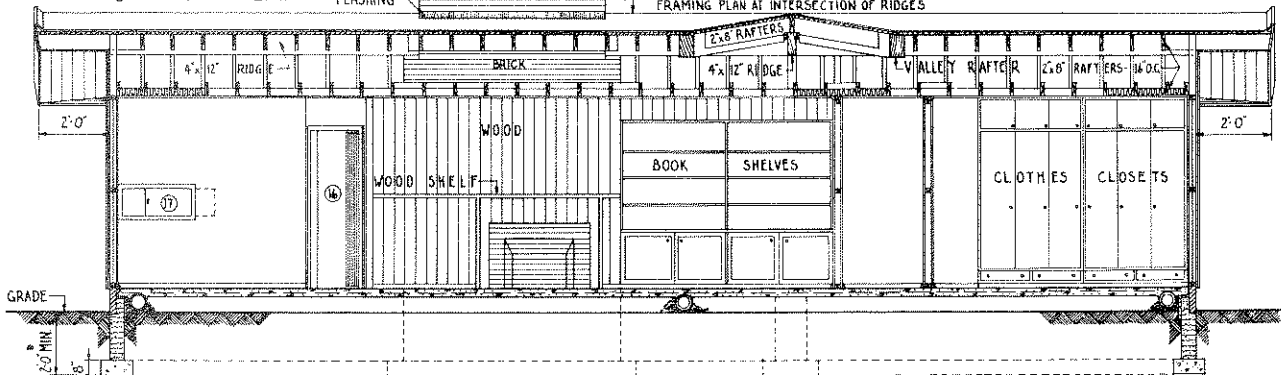

SECTION A-A

SCALE 0 2 4 6 FT.

* FOOTINGS SHALL BEAR ON SOLID GROUND BELOW FROST LINE

COOPERATIVE EXTENSION WORK IN AGRICULTURE AND HOME ECONOMICS DEPARTMENT OF AGRICULTURAL ENGINEERING UNIVERSITY OF MARYLAND AND UNITED STATES DEPARTMENT OF AGRICULTURE COOPERATING		
3 BEDROOM FARMHOUSE		
USDA 1958	EX. 7136	SHEET 1 OF 3

SEE DETAIL OF ROOF FRAMING
AT CORNER - SHEET NO. 3

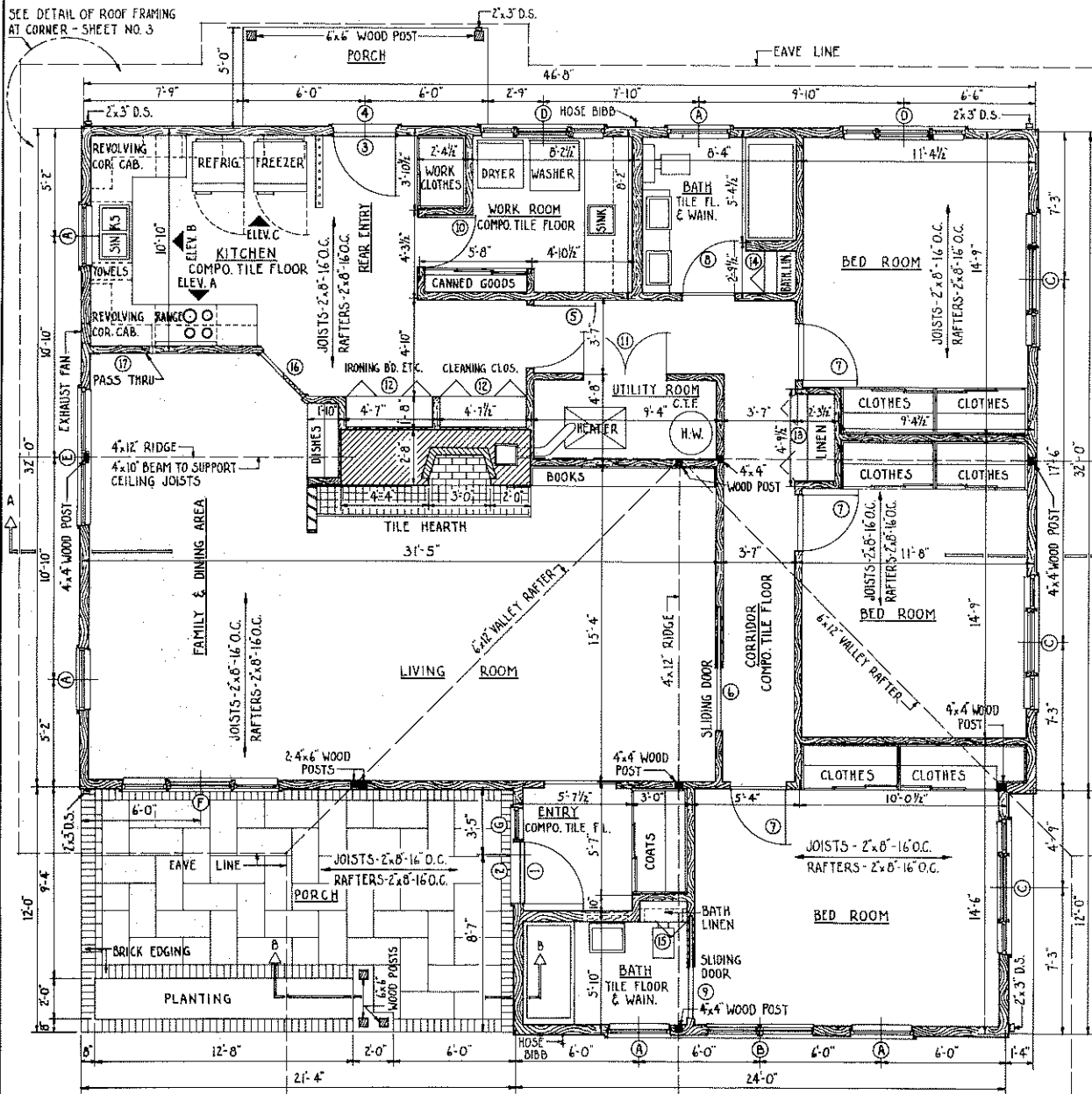

FLOOR PLAN

DIMENSIONS ARE SHOWN TO FACE OF STUDS

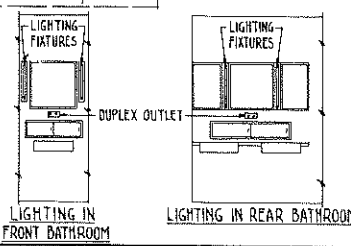
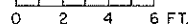

DOOR-SCHEDULE		
MARK	SIZE WIDTH HEIGHT THICK	DESCRIPTION
①	3-0 x 7-0 x 1 3/4	FLUSH PANEL-EXTERIOR
②	3-0 x 7-1 x 1 1/8	SCREEN-STORM COMBINATION
③	3-0 x 7-0 x 1 3/4	FLUSH PANEL-EXTERIOR-GLAZED
④	3-0 x 7-1 x 1 1/8	SCREEN
⑤	3-0 x 6-8 x 1 3/8	FLUSH PANEL-INTERIOR
⑥	3-0 x 6-8 x 1 3/8	" " " SLIDING
⑦	2-8 x 6-8 x 1 3/8	" " " " "
⑧	2-6 x 6-8 x 1 3/8	" " " " "
⑨	2-6 x 6-8 x 1 3/8	" " " " "
⑩	2-4 x 6-8 x 1 3/8	" " " " "
⑪	2-0 x 6-8 x 1 3/8	" " " " "
⑫	1-1 x 6-8 x "	SLATTED BI-FOLD-INTERIOR
⑬	1-0 x 6-8 "	" " " " "
⑭	1-0 x 6-8 "	" " " " "
⑮	1-2 x 3-0 "	" " " " "
⑯	3-0 x 6-8 "	ACCORDIAN TYPE
⑰	2-8 x 1-2 "	SLIDING

WINDOW-SCHEDULE		ELECTRICAL-KEY	
MARK	OPERATING SASH WIDTH HEIGHT	FIXED GLASS WIDTH HEIGHT	SYMBOL
①	3-1 x 3-2	1	1 RADIO AND TELEVISION
②	1-7 x 4-2	2	2 RANGE
③	1-7 x 3-2	1	3 REFRIGERATOR
④	3-1 x 4-2	1	4 FREEZER
⑤	2-8 x 4-2	1	5 DRYER
⑥	2-8 x 4-2	1	6 WASHER
⑦	1-7 x 5-3	1	7 HEATER OUTLET AND SWITCH
⑧			8 HOT WATER HEATER
⑨			9 EXHAUST FAN
⑩			10 WEATHER PROOF OUTLET
⑪			⊖ FLOOR OUTLET
⑫			⊖ FLUORESCENT FIXTURE
⑬			⊖ SPLIT WIRED OUTLET-3WIRE-120/240V
⑭			⊖ PUSH BUTTON
⑮			⊖ CHIMES
⑯			⊖ RECESSED CEILING FIXTURE

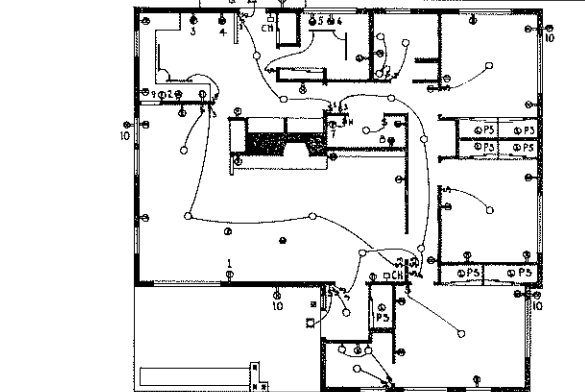

ELECTRICAL LAYOUT

COOPERATIVE EXTENSION WORK IN
AGRICULTURE AND HOME ECONOMICS
DEPARTMENT OF AGRICULTURAL ENGINEERING
UNIVERSITY OF MARYLAND
AND
UNITED STATES DEPARTMENT OF AGRICULTURE COOPERATING

3 BEDROOM FARMHOUSE

USDA 1958 | EX. 7136 | SHEET 2 OF 3

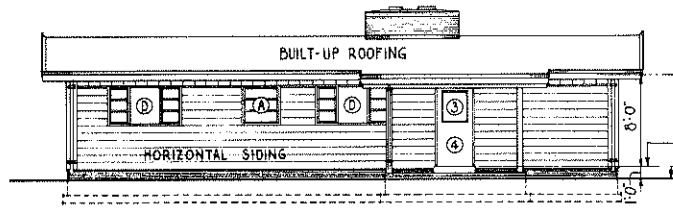

REAR-ELEVATION
SCALE 0 4 8 12 FT.

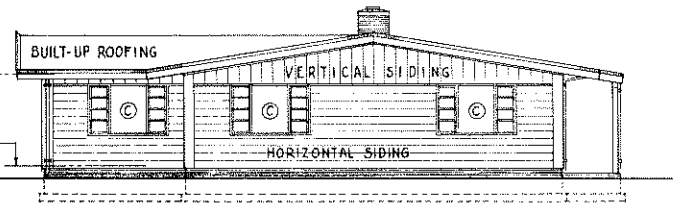

BED-ROOM-END-ELEVATION
SCALE 0 4 8 12 FT.

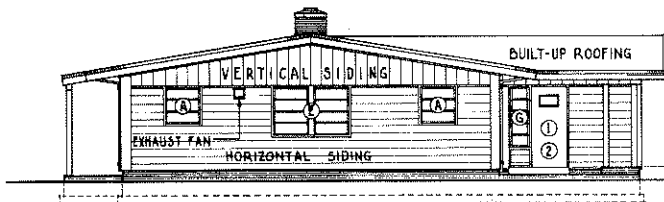

FAMILY-ROOM-END-ELEVATION
SCALE 0 4 8 12 FT.

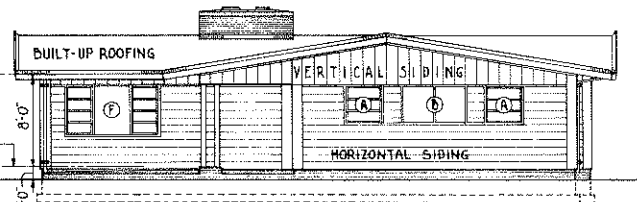

FRONT-ELEVATION
SCALE 0 4 8 12 FT.

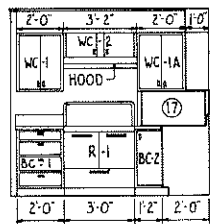

ELEVATION-A

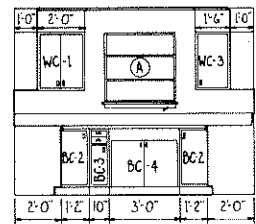

ELEVATION-B

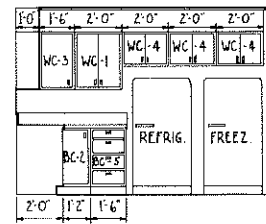

ELEVATION-C

KITCHEN ELEVATIONS
SCALE 0 2 4 6 FT.

KITCHEN - CABINET - SCHEDULE		
MARK	SIZE	DESCRIPTION
BC-1	24"W-24"D-36"H	4 DRAWER BASE CABINET
BC-2	36"W-36"D-36"H	REVOLVING CORNER BASE CABINET
BC-3	10"W-24"D-36"H	2 DRAWER BASE CABINET-DISH TOWELS BELOW
BC-4	36"W-24"D-36"H	2 BOWL SINK BASE CABINET
BC-5	18"W-24"D-36"H	4 DRAWER BASE CABINET
WC-1	24"W-12"D-30"H	WALL CABINET-A USED FOR EXHAUST DUCT
WC-2	36"W-12"D-12"H	SPACE FOR HOOD EXHAUST DUCT
WC-3	18"W-12"D-30"H	WALL CABINET
WC-4	24"W-12"D-18"H	WALL CABINET
R-1	36"W-24"D-36"H	RANGE

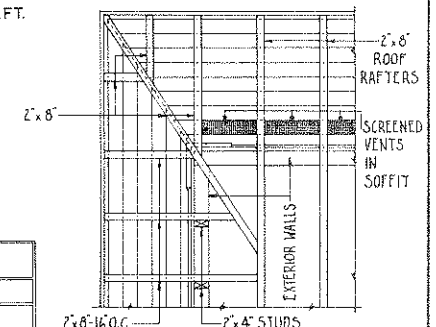

PLAN OF SOFFIT FRAMING SHOWING BOARD FINISH ON UNDER SIDE
SCALE 0 1 2 3 FT.

COOPERATIVE EXTENSION WORK IN
AGRICULTURE AND HOME ECONOMICS
DEPARTMENT OF AGRICULTURAL ENGINEERING
UNIVERSITY OF MARYLAND
AND
UNITED STATES DEPARTMENT OF AGRICULTURE COOPERATING

3 BEDROOM FARMHOUSE
USDA 1958 EX. 7136 SHEET 3 OF 3

7136 S on back

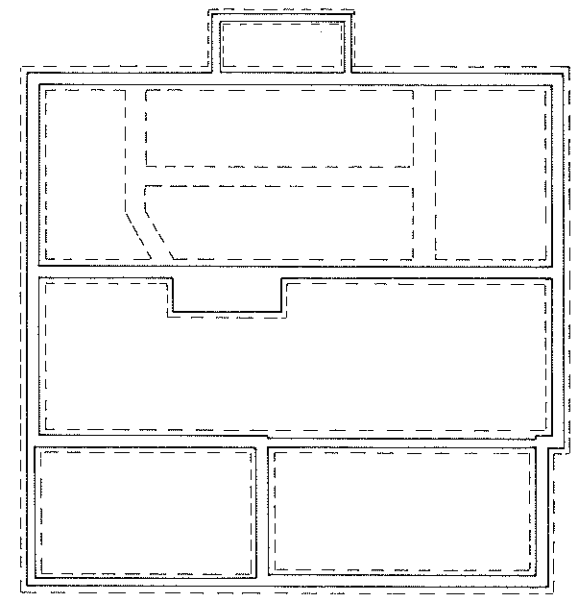
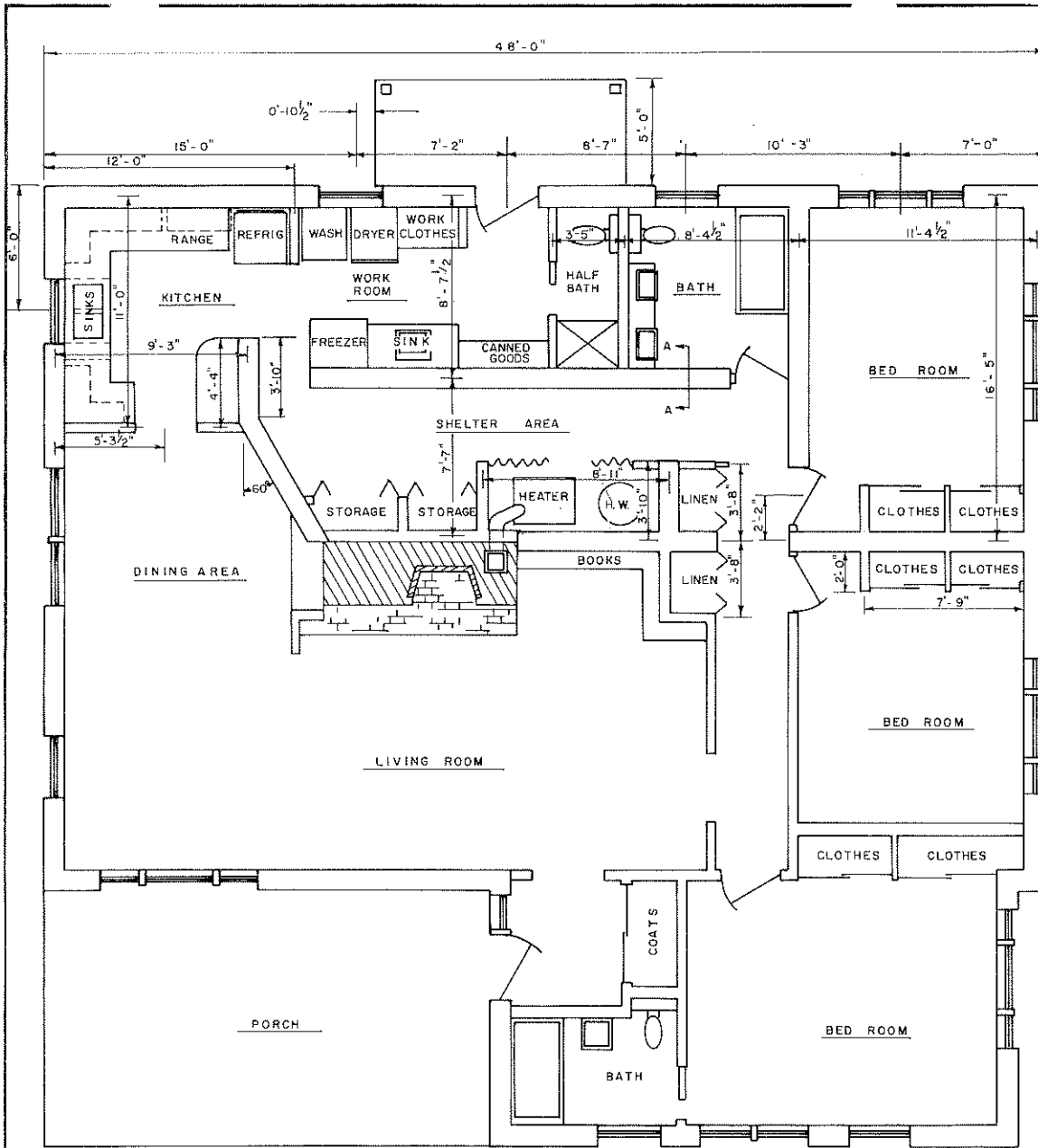

NOTE:
EXTERIOR WALL 4"
CONCRETE BLOCK
WITH 4" BRICK OR
STONE MASONRY
VENEER.

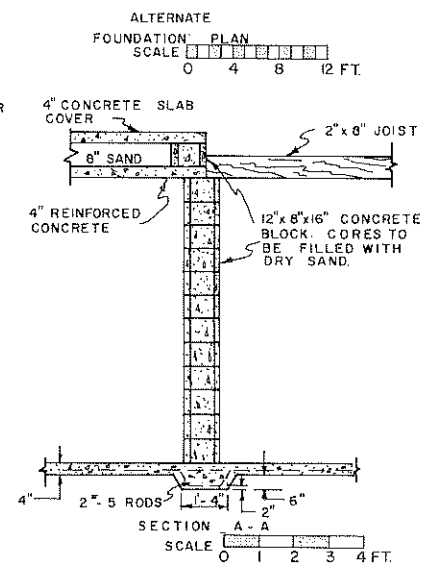

NOTE:
THE FAMILY FALLOUT SHELTER FOR 8 PEOPLE HAS A
PROTECTION FACTOR OF APPROXIMATELY 80

COOPERATIVE EXTENSION WORK IN AGRICULTURE AND HOME ECONOMICS DEPARTMENT OF AGRICULTURAL ENGINEERING UNIVERSITY OF MARYLAND AND UNITED STATES DEPARTMENT OF AGRICULTURE COOPERATING		
3 BEDROOM FARMHOUSE WITH FALLOUT SHELTER		
DATE 7/26/65	EX 7136S	SHEET 1 OF 1