

PERSPECTIVE (NOT TO SCALE)

4x6' CONC. STOOP
4" THICK SLAB

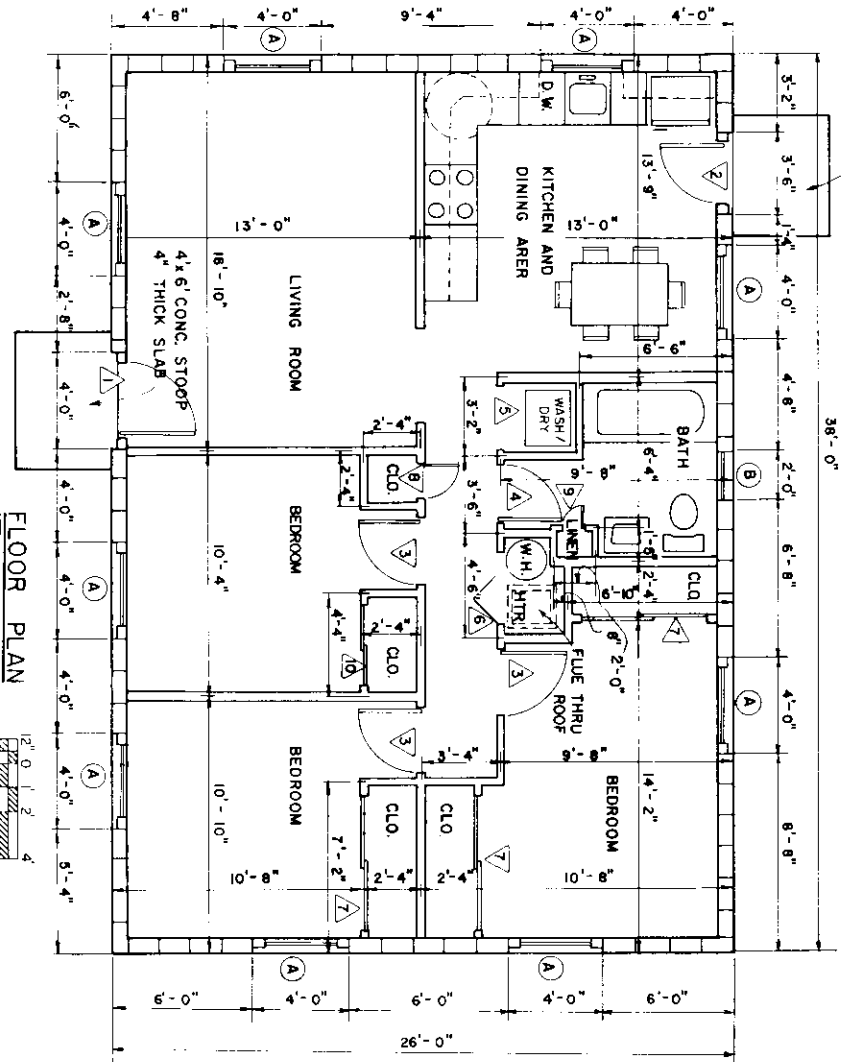

FLOOR PLAN

MARK	SIZE	DOOR SCHEDULE	TYPE	# REQ'D
1	3'-0" x 6'-8"	SOLID CORE EXTERIOR		1
2	2'-8" x 6'-8"	SOLID CORE EXTERIOR		1
3	2'-8" x 6'-8"	HOLLOW CORE INTERIOR		3
4	2'-8" x 6'-8"	HOLLOW CORE INTERIOR		1
5	2'-8" x 6'-8"	HOLLOW CORE INTERIOR		1
6	3'-0" x 6'-8"	BI-FOLD		1
7	5'-0" x 6'-8"	WOOD SLIDING		3
8	1'-6" x 6'-8"	HOLLOW CORE INTERIOR		1
9	1'-0" x 6'-8"	HOLLOW CORE INTERIOR		1
10	3'-0" x 6'-8"	WOOD SLIDING		1

MARK	SIZE	WINDOW SCHEDULE	TYPE	# REQ'D
A	3'-0" x 4'-2"	WOOD DOUBLE HUNG		9
B	2'-0" x 2'-0"	WOOD ANNING		1

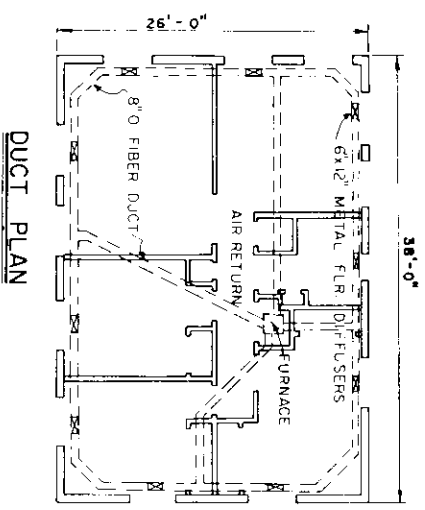

DUCT PLAN

NOTE: THE 8" CONCRETE BLOCK, R 15 SLIGHTLY MORE THAN 10R-2 FOR LIGHT WEIGHT BLOCKS. FOR COLD WEATHER USE, BLOCK WILL NEED TO BE FACED WITH 2" OF RIGID INSULATION (R10 OR 11). IF ON THE INSIDE, WINDOW SETTING WILL NEED ADJUSTMENT. PROTECTIVE COATING WILL BE NEEDED FOR EITHER INTERIOR OR EXTERIOR PLACEMENT.

COOPERATIVE EXTENSION SERVICE
AGRICULTURE AND HOME ECONOMICS

UNITED STATES DEPARTMENT OF AGRICULTURE COOPERATING
AND
3 BEDROOM MASONRY HOUSE

USDA 70 7197 SHEET 1 OF 3

REV 86

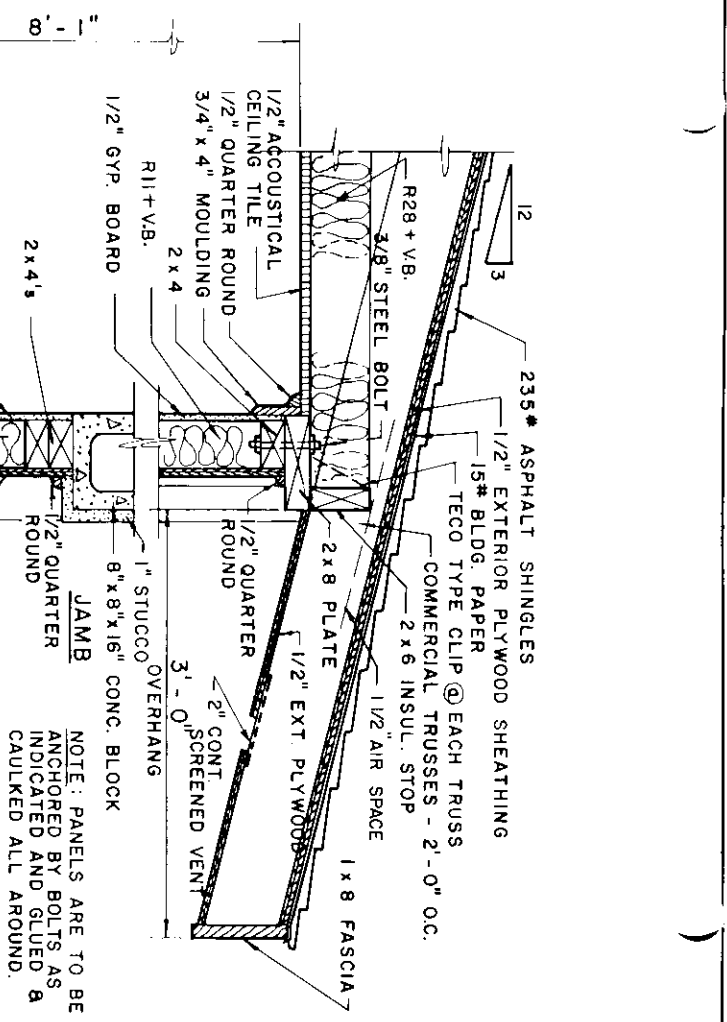

NOTE: PANELS ARE TO BE ANCHORED BY BOLTS AS INDICATED AND GLUED & CAULKED ALL AROUND.

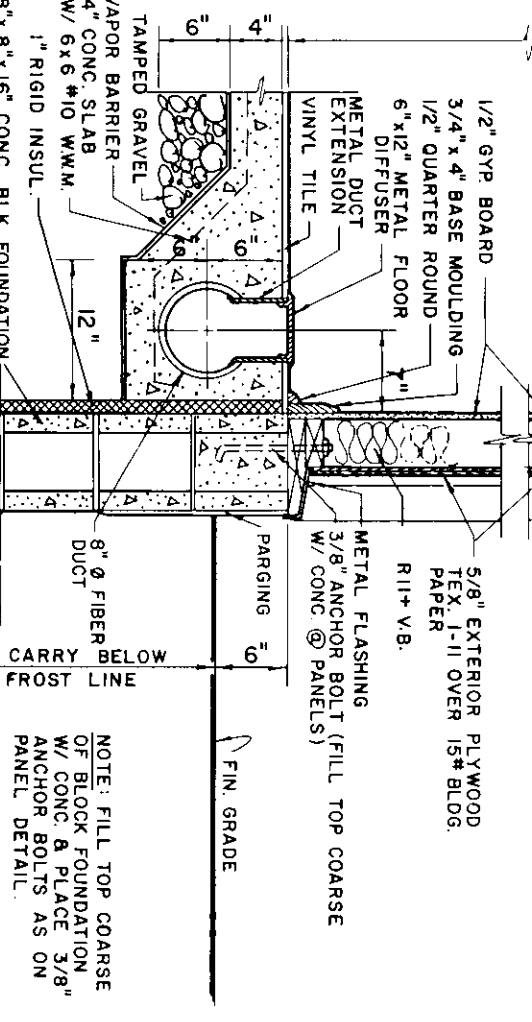

NOTE: FILL TOP COARSE OF BLOCK FOUNDATION W/ CONC. & PLACE 3/8\"/>

TYPICAL SECTION THRU WINDOW PANEL

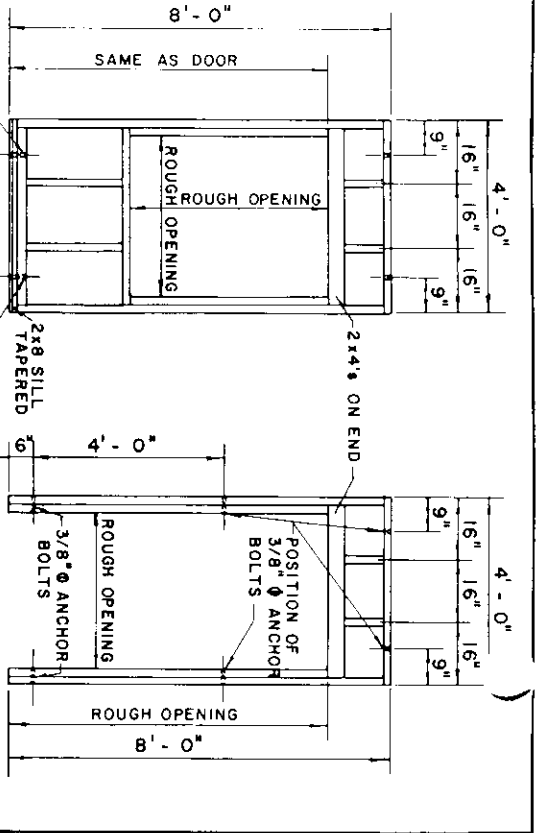
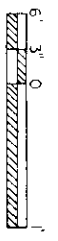

NOTE: ALL FRAMING 2x4's UNLESS NOTED.

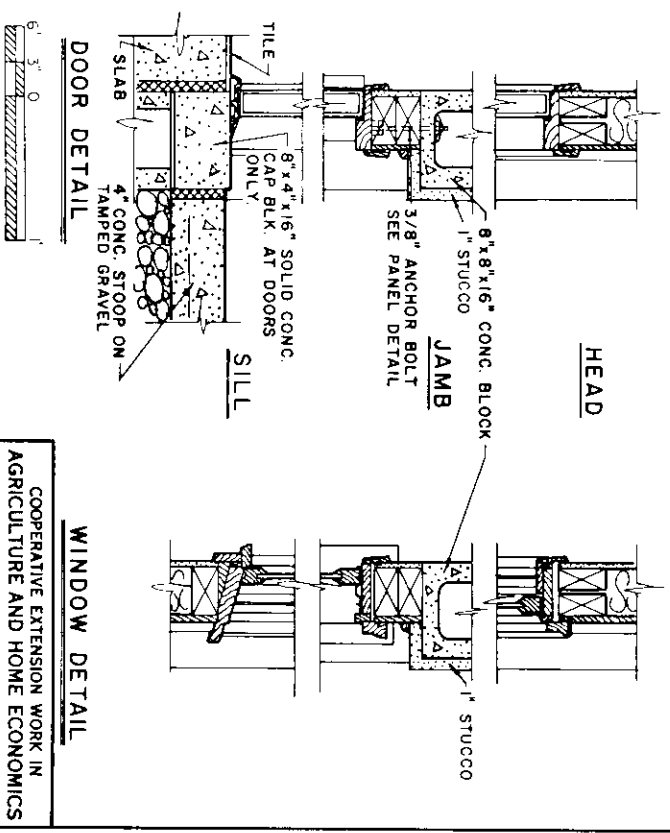

WINDOW DETAIL

COOPERATIVE EXTENSION WORK IN AGRICULTURE AND HOME ECONOMICS
 UNITED STATES DEPARTMENT OF AGRICULTURE COOPERATING

3 BEDROOM MASONRY HOUSE			
USDA '70	7197	SHEET 2 OF 3	
REV	'86		

NOTE: CONVENTIONAL RAFTER AND CEILING JOISTS WOULD BE A SATISFACTORY ALTERNATIVE

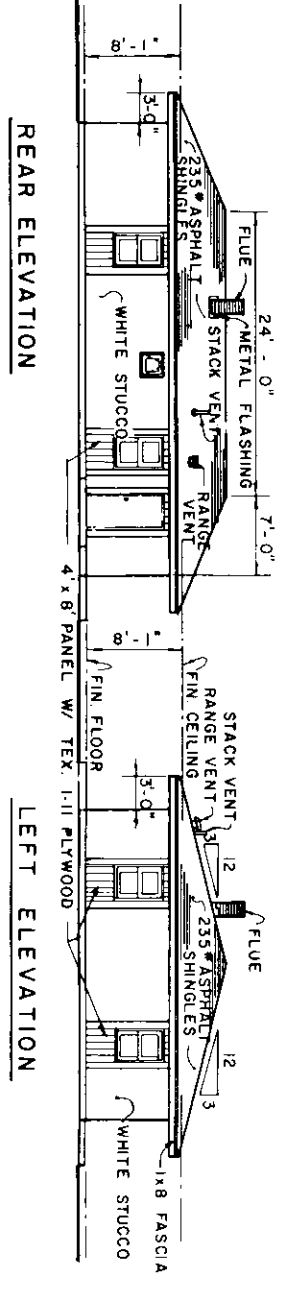
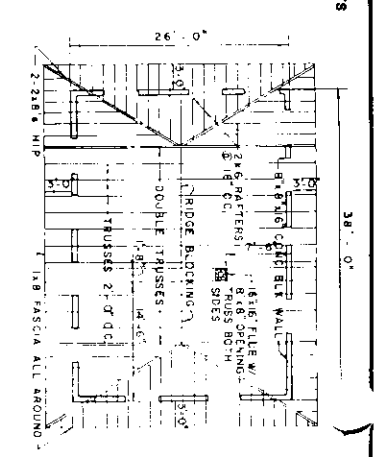
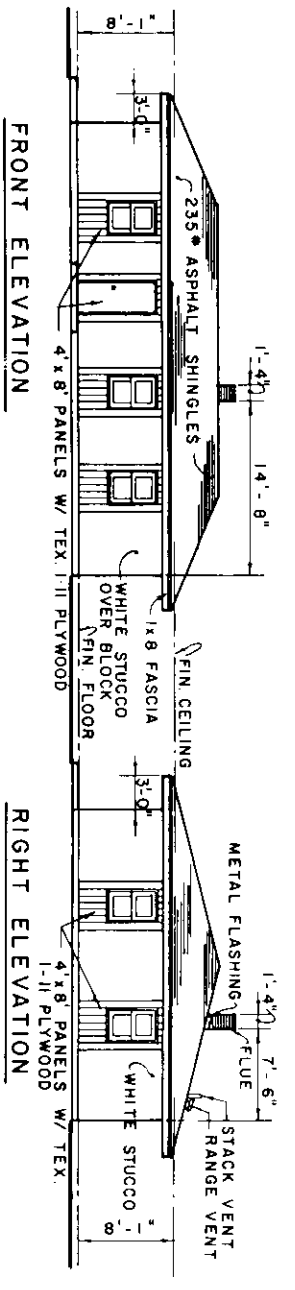

ROOF FRAMING PLAN (NOT TO SCALE)

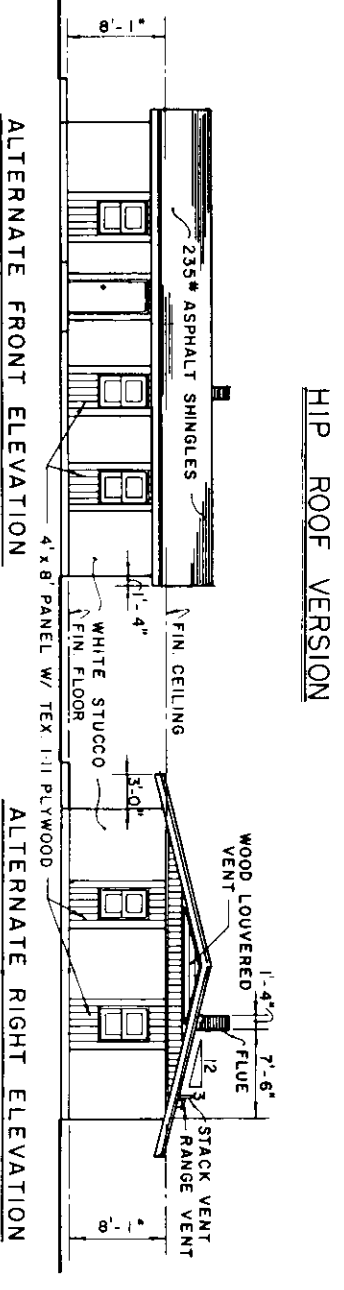

HIP ROOF VERSION

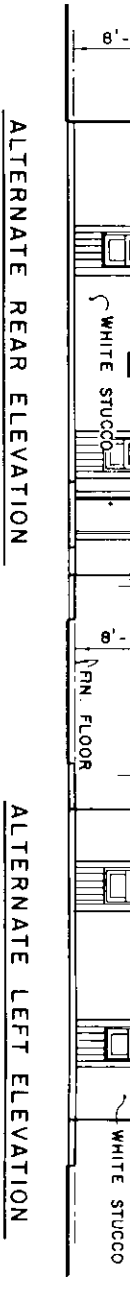
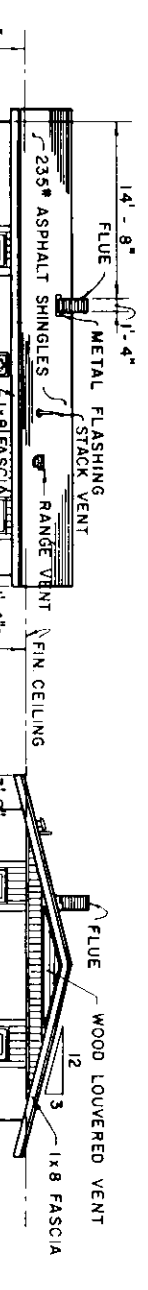

TYPICAL SECTION THRU BLOCK WALL

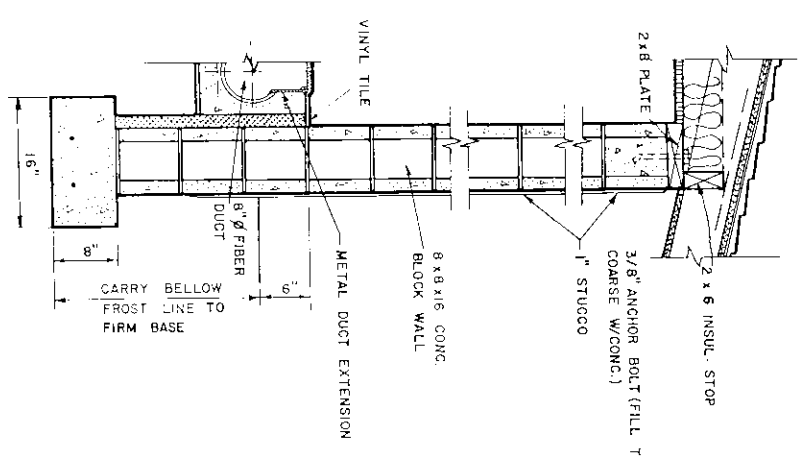

12'-9" 6" 3" 0"

COOPERATIVE EXTENSION SERVICE
AGRICULTURE AND HOME ECONOMICS

UNITED STATES DEPARTMENT OF AGRICULTURE COOPERATING

3 BEDROOM MASONRY HOUSE

USDA '70 7197 SHEET 3 OF 3

REV '86

ALTERNATIVE GABLE ROOF VERSION

ALTERNATE REAR ELEVATION

ALTERNATE LEFT ELEVATION

ALTERNATE FRONT ELEVATION

ALTERNATE RIGHT ELEVATION

REAR ELEVATION

LEFT ELEVATION

FRONT ELEVATION

RIGHT ELEVATION